

DROP ZONE AUTO TOWER

Tower Part # C913-1900/w, 1901/w, 1902/w
Trailer bracket # C913-1929 (not shown)
Bimini Part # C813-1921, C813-1913
Bimini Part # C813-1925, C813-1913/1915 (not shown)
Bombshell Racks and swivels # C913-1904
Rack Adapter # C913-1905
Coverfire Speakers # C913-1906/w

Information: info@roswellmarine.com
Warranty: warranty@roswellmarine.com

If you have any questions please call : 1-321-638-1331



TABLE OF CONTENTS

About your tower _____ **03**

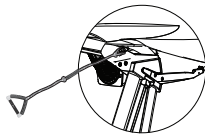

Tower Features _____ **04-06**

BIMINI(s) _____ **07-12**



Folding Bimini ____ pg 07

Un-Folding Bimini ____ pg 09

Tips & Tricks _____ pg 11

General Info _____ pg 12



Folding Tower + Trailering _____ **13-17**

Folding Tower ____ pg 13

Transport + Storage _ pg 15

Loss of Power ____ pg 17-19



Bombshell Racks _____ **20-24**



Audio _____ **25-28**

Tower Troubleshooting

Weight Assist _____ **29-30**

Actuator Adjustment _____ **31-32**

Wiring Diagrams _____ **33-35**

GENERAL TOWER CARE & MAINTENANCE

This product is to be used for the sole purpose of wakeboarding, wakesurfing, hydrofoiling, and kneeboarding.

The tower is intended to center tow a maximum of two wake boarders at one time and no more than 400lbs (181kg) collectively, side tow a maximum of one wakesurfer at a time 250 lbs (114kg)

Check all tower hardware before every use on the water. We recommend keeping a set of Allen wrenches on your boat for this purpose. Verify that all bolts, screws, and nuts are tight. Even with thread-locker they may loosen over time.

Never attach a tow rope to anything other than the tow heads.

Do not use the board racks as entry/exit handles to get in and out of the boat – they are not designed for this purpose.

Never hang from the tower or speakers. Do not climb or sit on the tower.

Be aware of the tow rope at all times. Ensure that it is not attached to anything on the tower other than the tow head, and that the rope is clear of any cleats or objects on the boat before pulling the rider up and out of the water.

Never travel at speeds in excess of 30mph / 48kph (i.e. towing the boat on a trailer) or through extremely rough water with wakeboards, wakesurfers, skis, etc. In the racks.

Never travel at speeds in excess of 30mph / 48kph (i.e. towing the boat on a trailer) or through extremely rough water with the bimini in it's deployed state. ONLY travel with the bimini in it's folded state secured to the tower.

Be cautious when driving your boat on the water or on a trailer if you have board racks. They may decrease your clearance into a garage or slip. Rotate board racks inboard.

Check the clearance between your tower and any overhead obstacles including bridges, canals etc.

NEVER USE CLEANERS ON YOUR TOWER OR ACCESSORIES! Your Roswell tower has been treated with an automotive paint coating that forms a protective layer. A mild soap and water combination may be used to remove traveling grime or water spots. Clean with each use. Use only a soft cloth and never use any chemical cleaners. Treat as you would your vehicle. Wax to protect finish.

Happy Boating

TOWER FEATURES

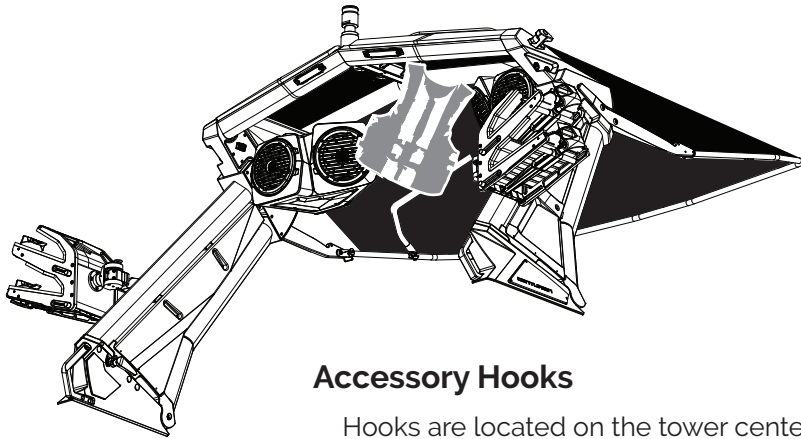

Accessory Hooks

Hooks are located on the tower center section and provide 4 spots to hang your water sports accessories, exclusive to Centurion.

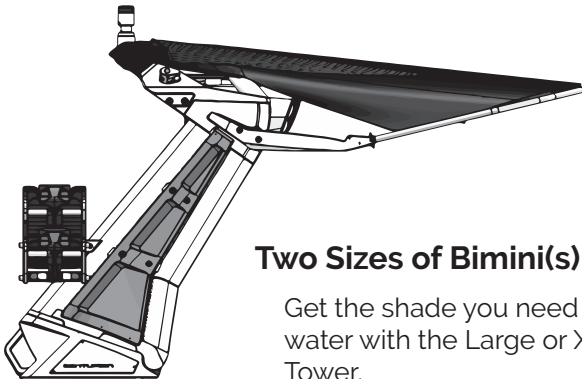
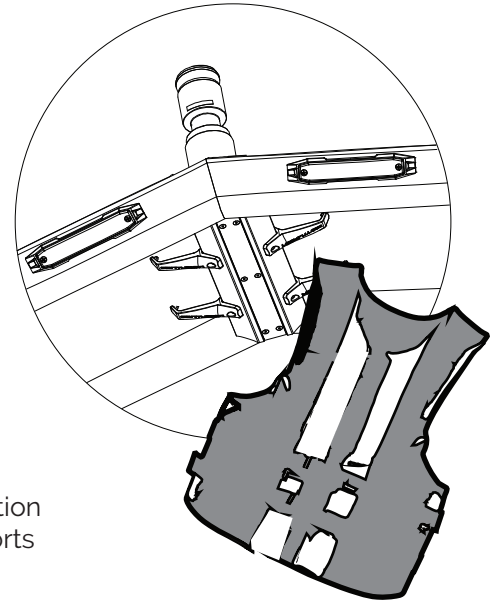

Two Sizes of Bimini(s)

Get the shade you need when out on the water with the Large or XXL Bimini for your Tower.

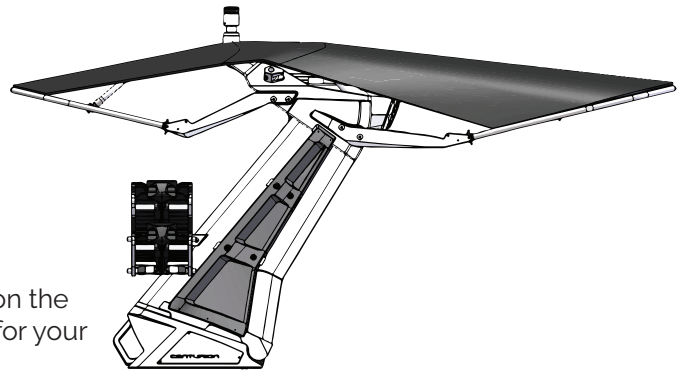

NOTE: More Information on Page 07-12

Surf Pockets

Surf pockets are a great place to store extra Surfboards. When storing the boards make sure the nose goes in first with the fin pointing to the sky. Lock the boards in place by securing the bungee strap around the fin(s) of the board.

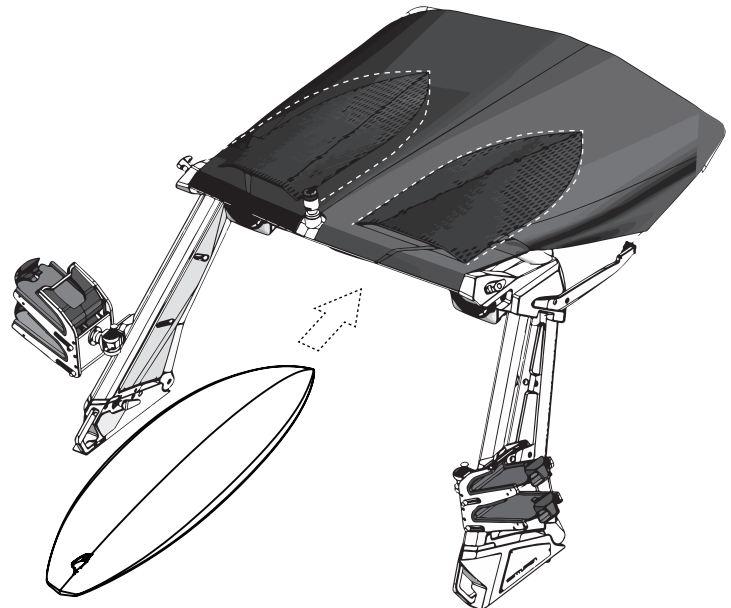

TOWER FEATURES

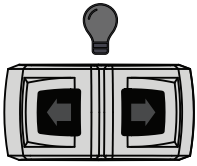

Light off

Indicates that your Cam latches are engaged and there is no power to the actuators.

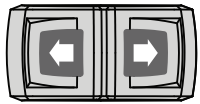

Light on

Indicates that the tower is able to fold.

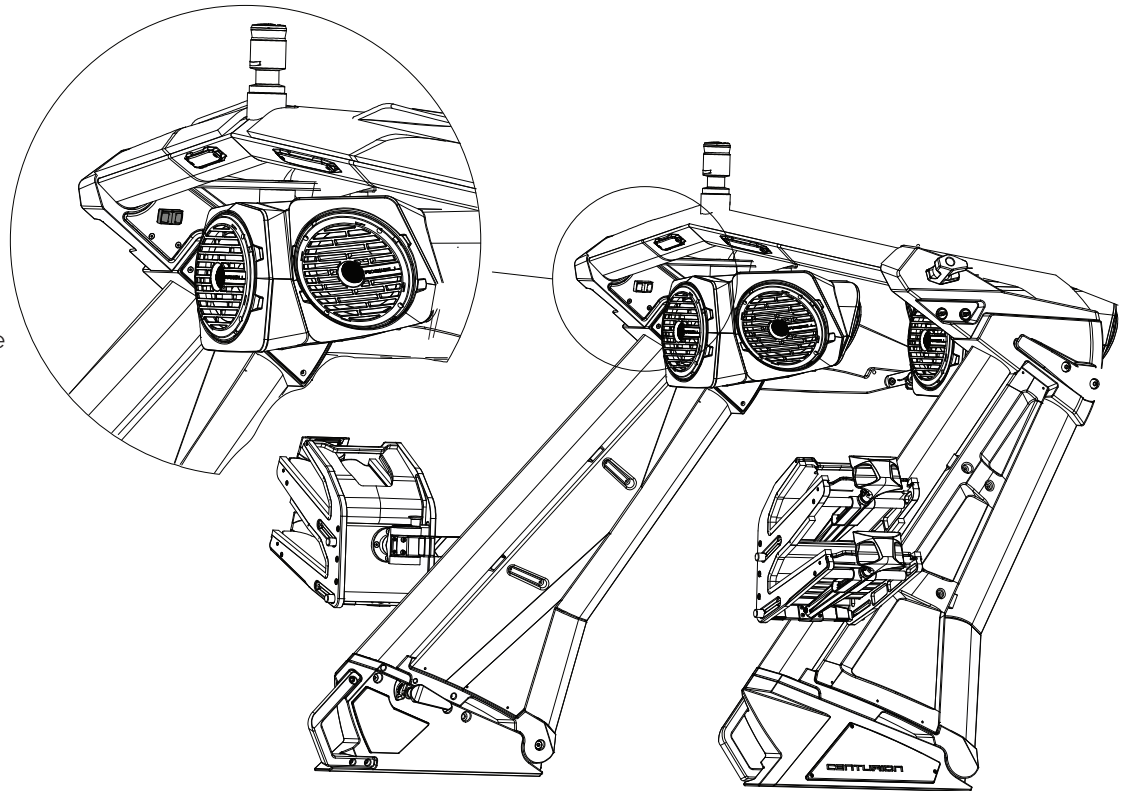

Power Folding Tower

Putting your tower down just got a whole lot easier with the Drop Zone Auto Tower. First unlock your cam latches to activate the switch located on the port side by the speakers. The switch will light up when it is ok to start folding or raising the tower by pressing the designated direction for raising or lowering the tower.

NOTE: More Information on Page 13-17

2 Surf Tow Heads

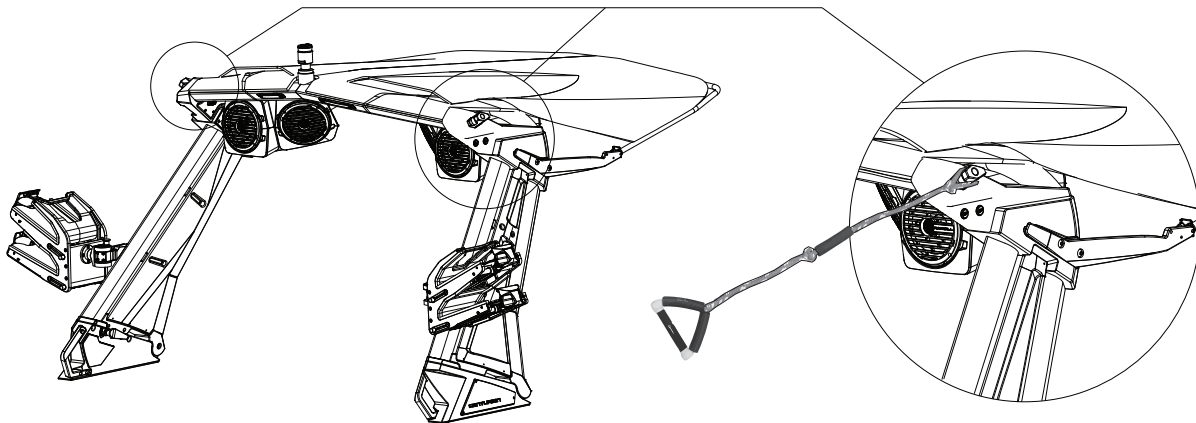

Surf Tow Heads

Why be in the wake when you can be on it. The surf tow heads make it easier to get up without the wash of the wake and allows you to be on the side of the wake before you even start.

TOWER FEATURES

Grab Handles

Integrated into the tower, the grab handles give you a comfortable place to grab in the boat or when maneuvering the boat.

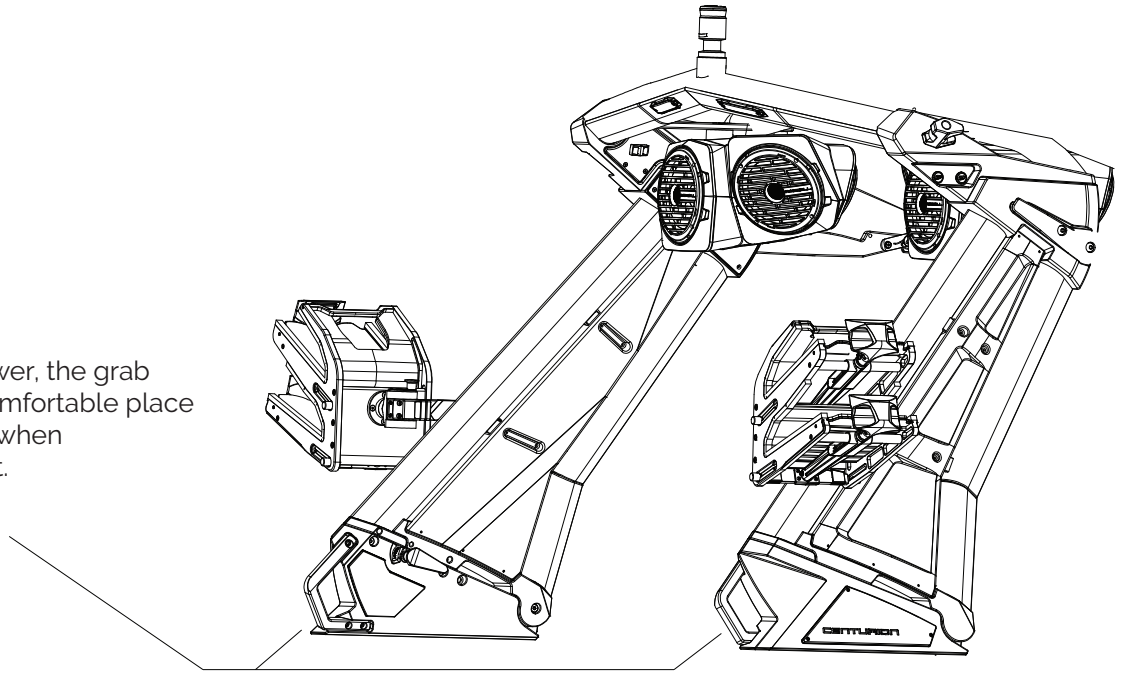

Bombshell Strapless Rack

The Bombshell Rack makes it easy to get your boards in and out with the exclusive strapless rack designed for this tower. First set your board into the tine then pull the clamp to secure your board.

In the narrow setting, the max board width should be **no greater than 20"** and **no less than 14"**.

In the wide setting, the max board width should be **no greater than 23"** and **no less than 17"**.

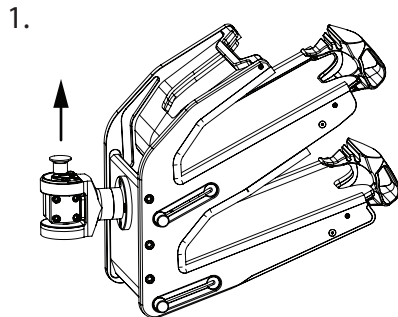
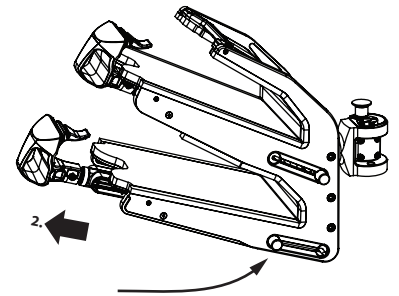
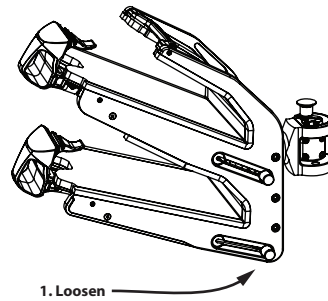
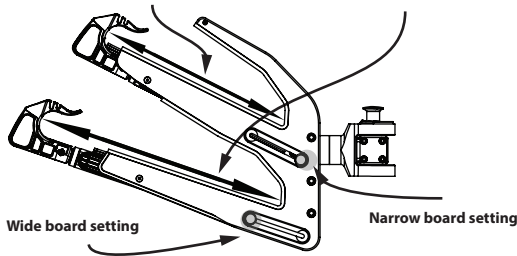

Lift pin to unlock swivel

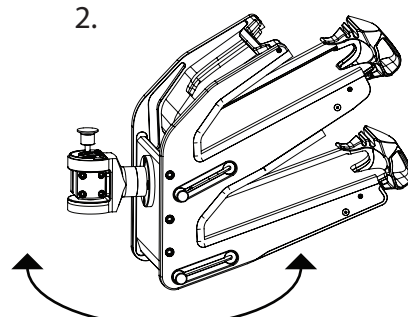

Rotate Rack 180° to second position

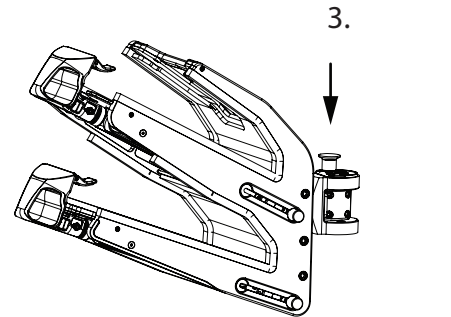

Push rack to compress rubber and the pin will drop in lock hole

NOTE: More Information on Pages 18-22

CENTURION

Bimini Instructions
Bimini Boot / Folding Tower
Safe Trailering with Bimini

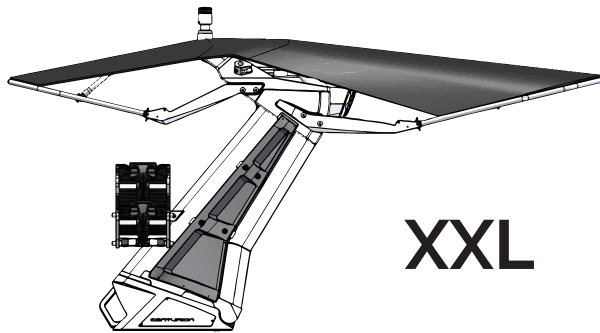

XXL

Bimini Part # C813-1925, C813-1913/1915

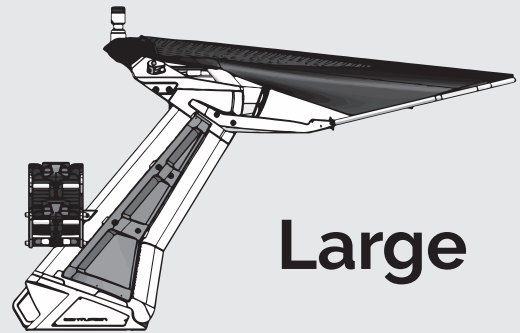

Large

Bimini Part # C813-1921, C813-1913

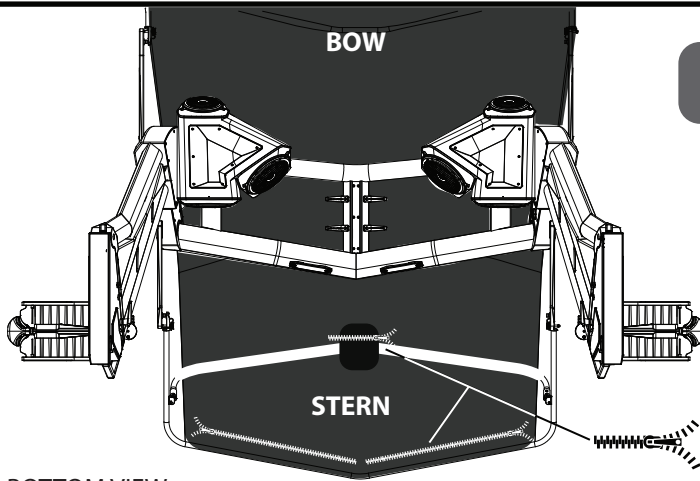

BOTTOM VIEW

Unzip the rear Bimini from the frame.

1

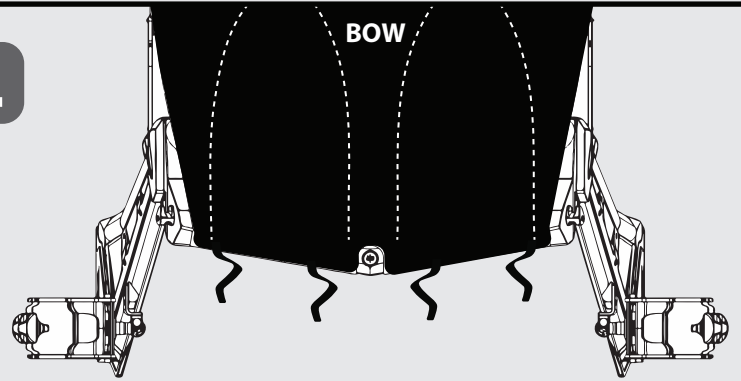

TOP VIEW

Unfasten the rear Bimini straps from the frame.

2

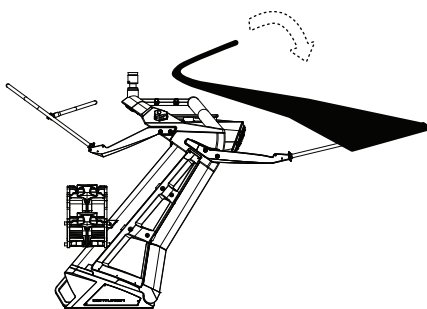

Roll/Wrap the canvas around the front bimini Frame.

Once the canvas is wrapped around the front frame remove the quick release pins and drop the bimini down. Once down grab the boot and zip it over the frame and canvas.

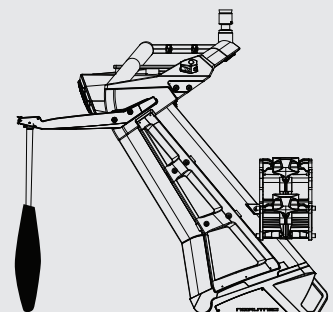
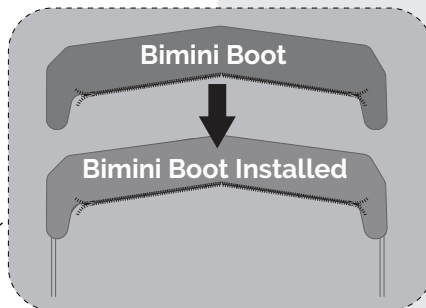
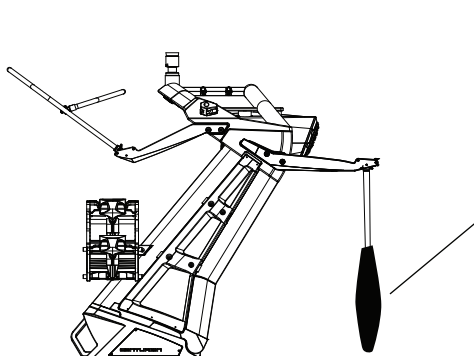
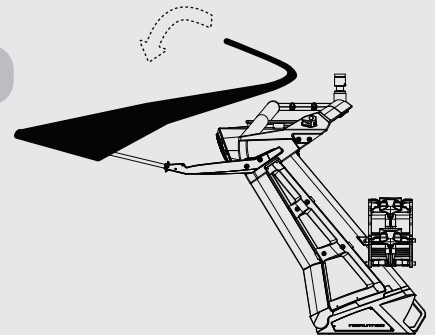

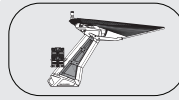
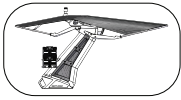

3

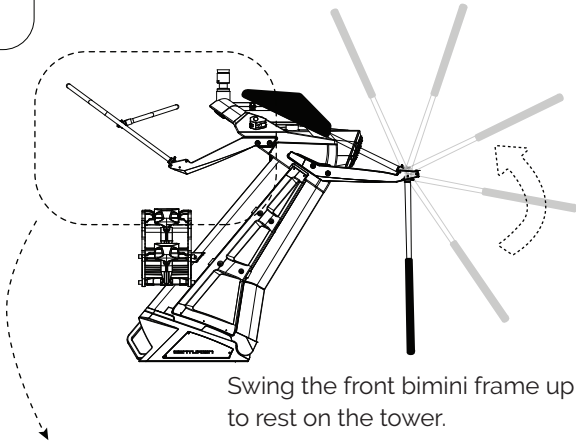

Swing the front bimini frame up to rest on the tower.

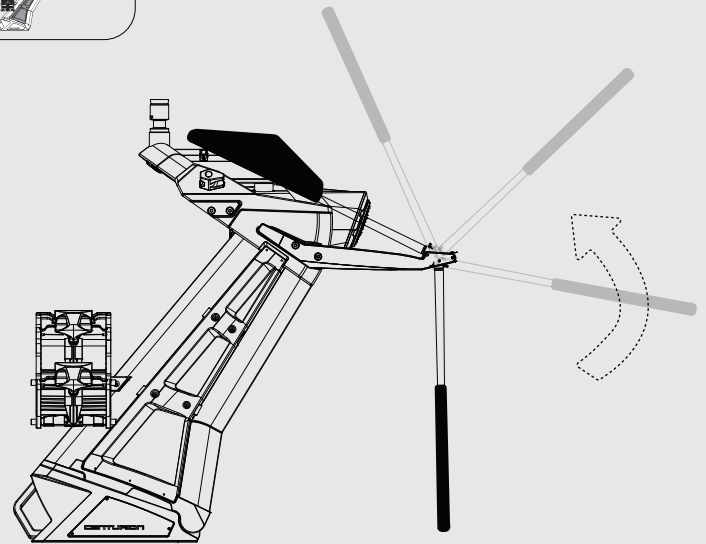

Swing the front bimini frame up to rest on the tower.

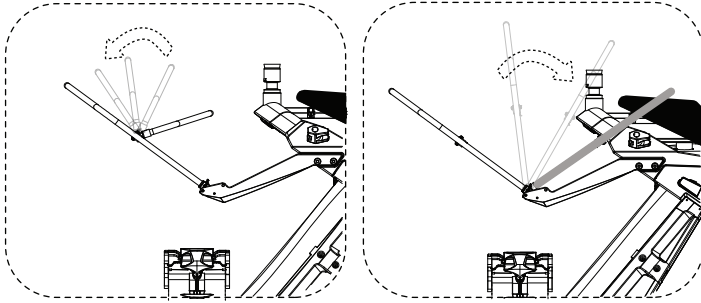

Swing the rear support back to nest in the rear bimini frame. Then swing the rear bimini frame on top of the front bimini frame and boot.

4

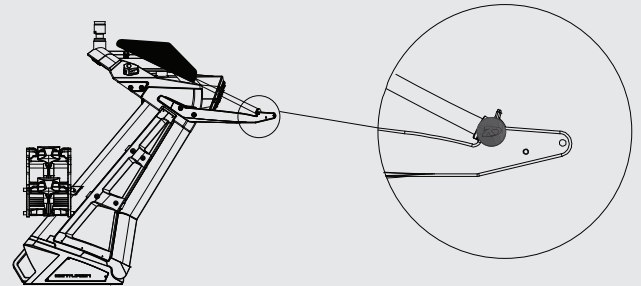
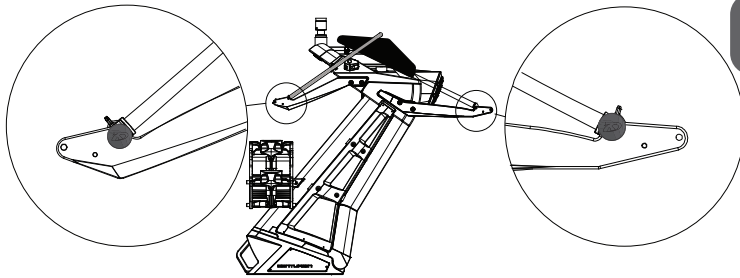

Now that your boot and frame are resting on the tower take the quick release pins and install them in the folded position.

5

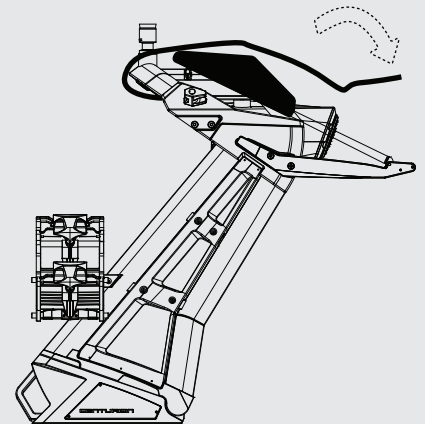
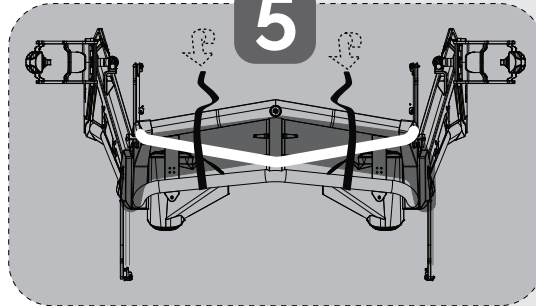
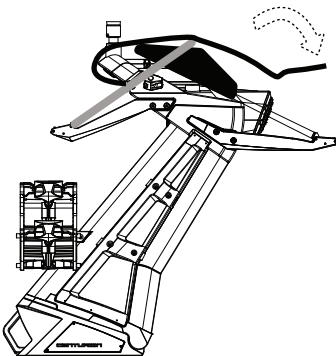

Take the straps from the bimini boot and wrap them around the tower, frame(s) and boot to secure them.

Un-Folding Bimini

1

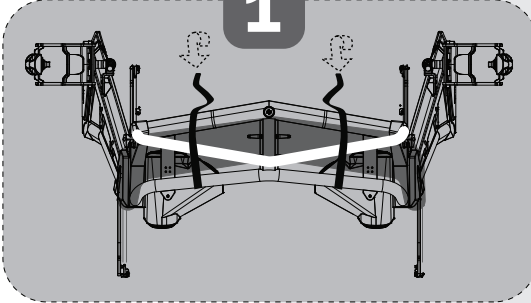

Remove boot straps.

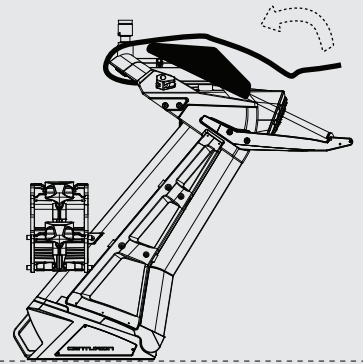
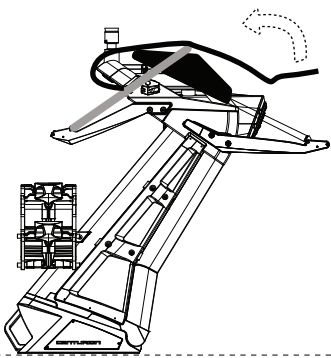

2

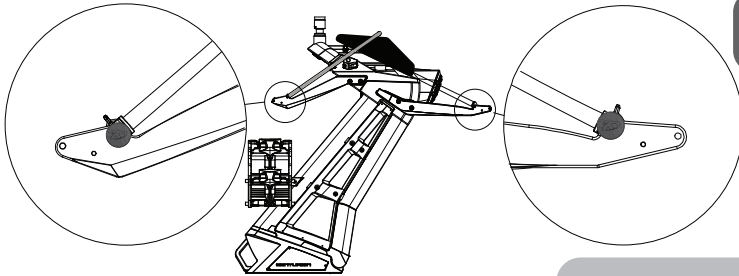

Remove pins out of folded position.

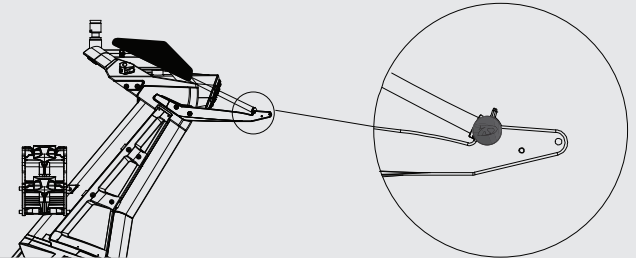

3

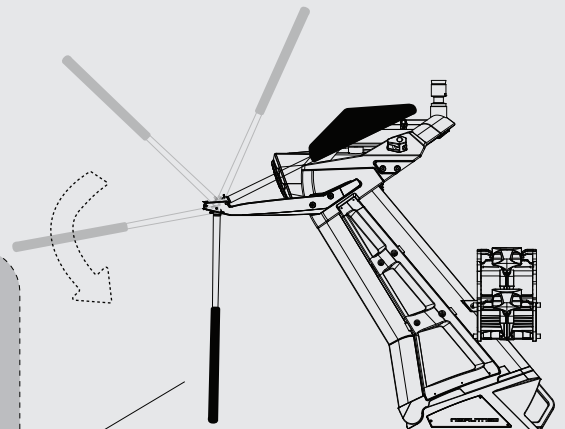
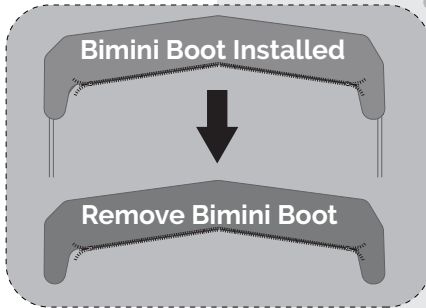
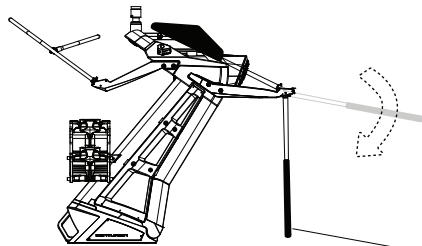
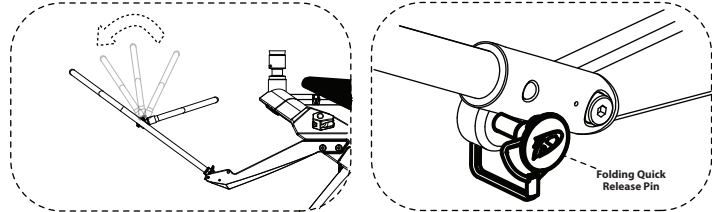

Start by unfolding the rear frame and install the release pin into its outstretched position so that the frame can sit on top of the quick release pin. Next unfold the front frame and bimini, then remove boot cover.

Once the straps and quick release pins are removed swing the bimini frame and boot forward and remove the boot.

4

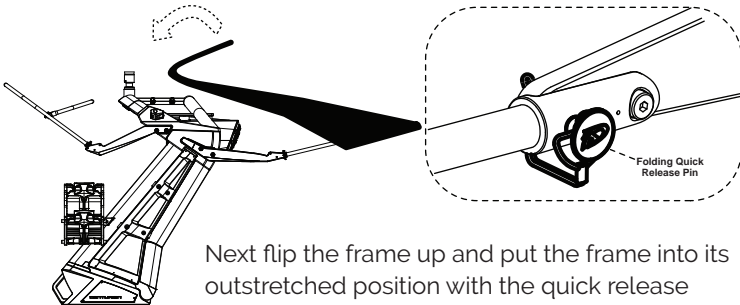

Next flip the frame up and put the frame into its outstretched position with the quick release pins. Then take the canvas and stretch the material back to the rear frame.

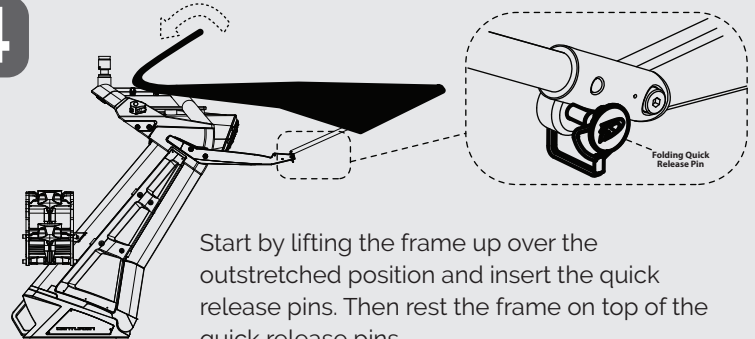

Start by lifting the frame up over the outstretched position and insert the quick release pins. Then rest the frame on top of the quick release pins.

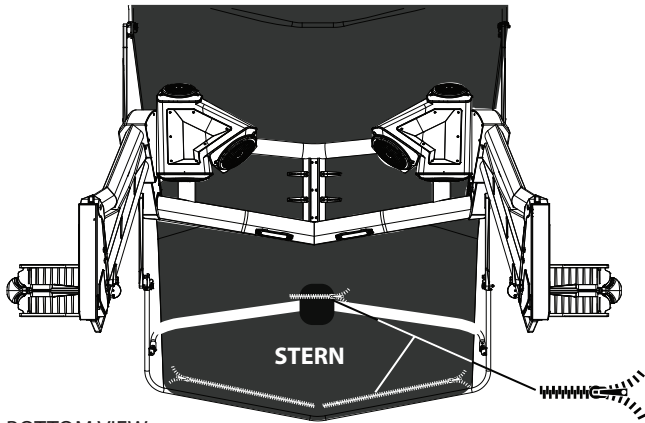
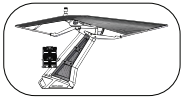

BOTTOM VIEW

Zip the bimini canvas to the rear frames.

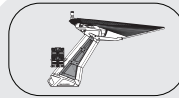

5

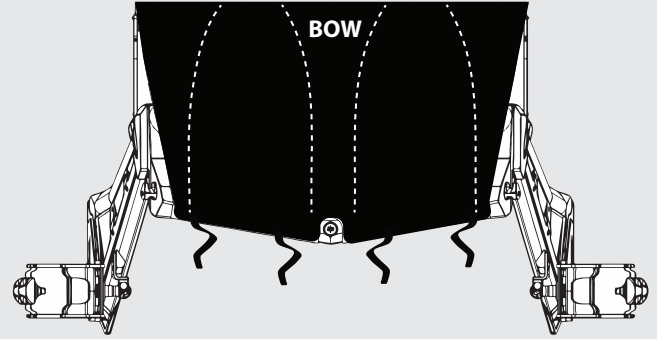

TOP VIEW

Tightly wrap the Velcro straps around the center section.

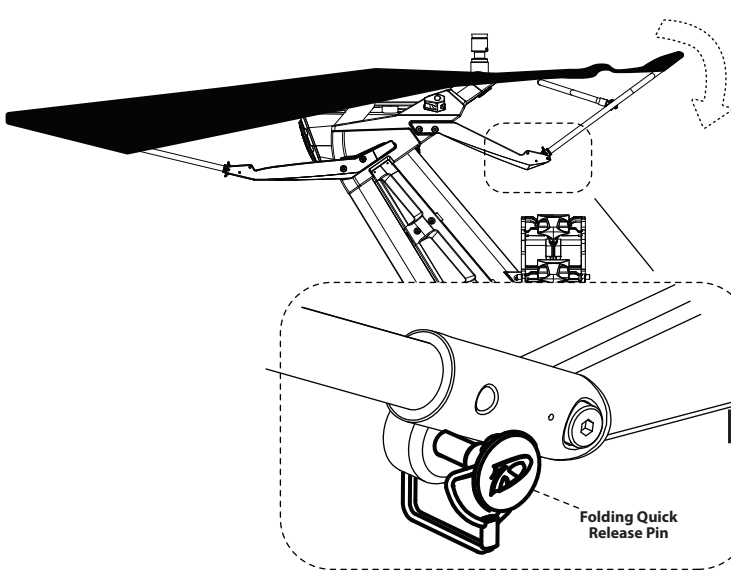

6

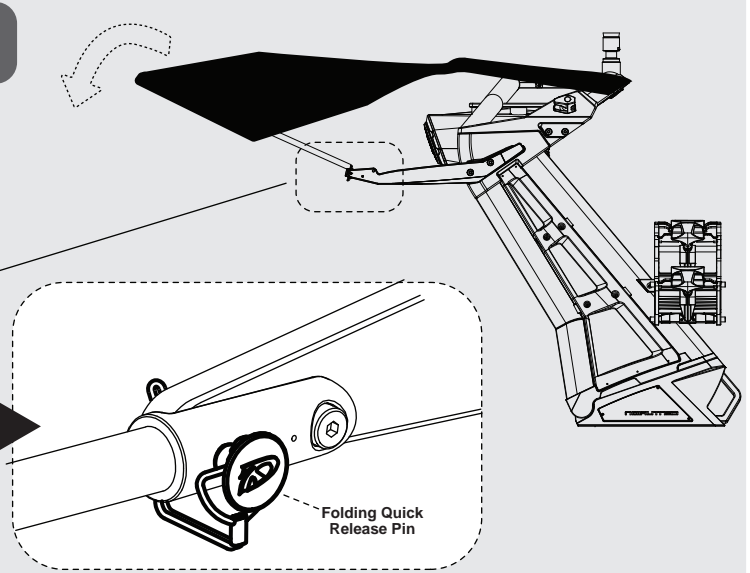

Now that the bimini is attached remove the quick release pins and pull down on the bimini frame to tighten the canvas and install the frame in its outstretched position using the quick release pins.

7

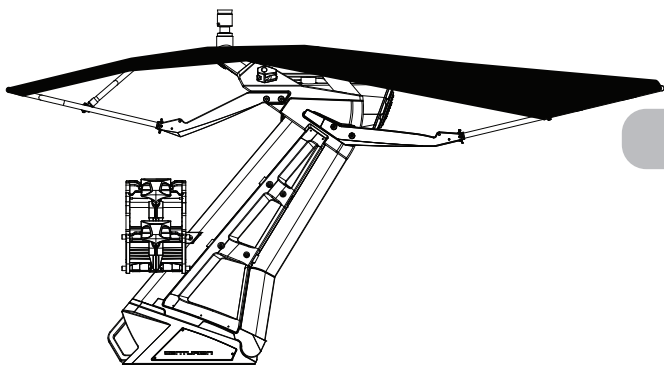

Happy Boating

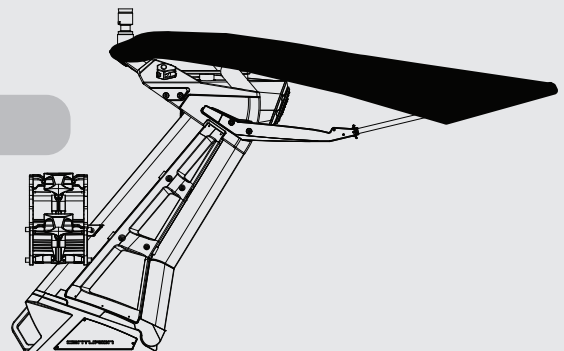

Tips & Tricks for Your Tower Bimini

T

It is normal that there is potentially a slight variation from one tower bimini to another. Listed below are some tips and tricks to ensure that your bimini is installed and functioning properly. This process is not mandatory for all bimini.

1 : It is possible that once your bimini is installed your frame and arms are not parallel where they pivot. This could make inserting and removing your quick release pins difficult. If you are not experiencing any issues, skip this page.

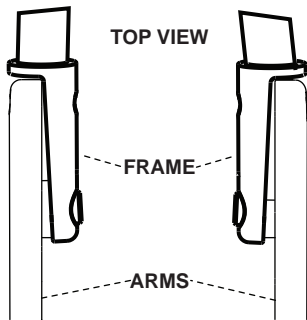

If your bimini looks like this, in Step 2 you will need to add shim washers between the forward bimini mounts and your bimini arms

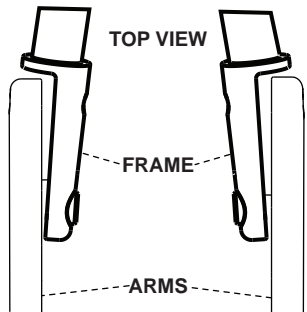

If your bimini looks like this, in Step 2 you will need to add shim washers between the rear bimini mounts and your bimini arms

2 : Choose one side of your tower to work on first. Determine which bimini mount point the shim washers will need to be added to. Completely remove the bolt that secures the bimini arm to your chosen bimini mount. Loosen the other bimini arm bolt. Add the shim washer(s) in between the chosen bimini mount and bimini arm. (In some cases 2 washers may be required under each arm) Re-insert the bolt with threadlocker applied. Remove the loosened bolt, apply threadlocker and re-insert. Tighten down the front and rear Bimini arm bolts in the same position they were in prior to loosening them. Repeat on the other side of your tower.

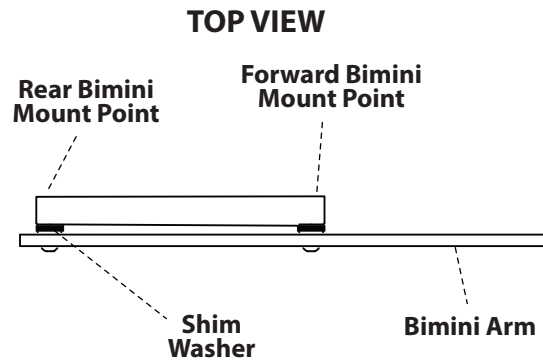

3 : Now that your shim washers have been added your frame and arms should be parallel or much closer. Test removing and inserting your quick release pins. If it is still difficult to remove or insert the pins proceed to the next step.

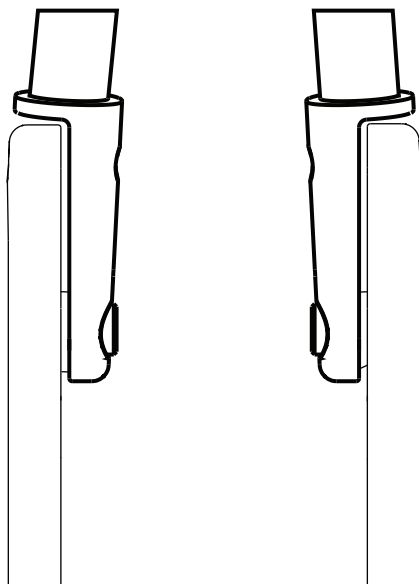

4 : If your quick release pins are still difficult to remove and insert with the addition of the arm shim washers, Roswell recommends using a drill with a 5/16" drill bit to clean out the holes. Drill through the frame and bimini arms at the same time. This will help with the alignment and ensure an accurately aligned hole.

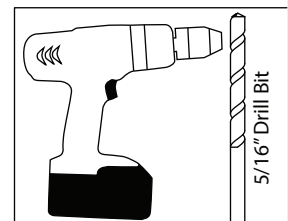
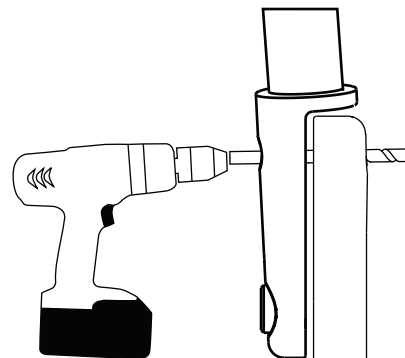

Important

Read & follow these instructions carefully. Failure to do so may result in damage to parts. Damage to parts from improper use is not covered under warranty.

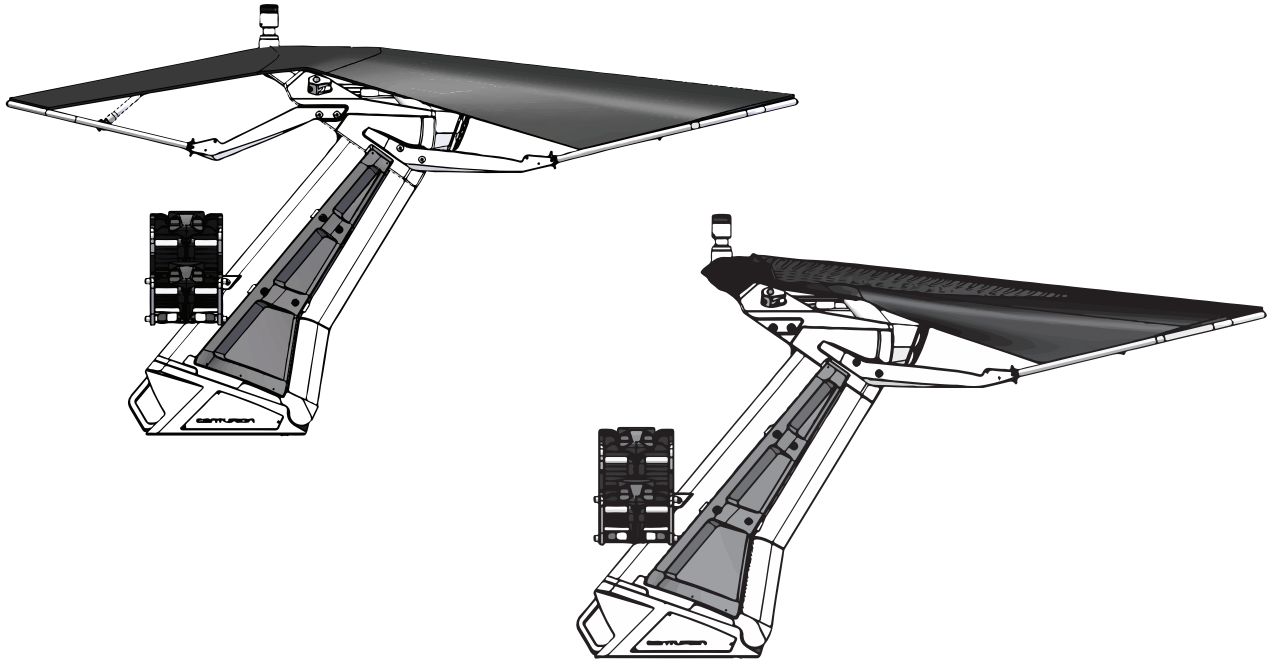

GENERAL BIMINI CARE & MAINTENANCE

Check all Bimini hardware before every use on the water. We recommend keeping a set of Allen wrenches on your boat for this purpose. Verify that all bolts are tight. Even with threadlocker they may loosen over time.

Watch your head when walking under the tower & bimini

NEVER USE CLEANERS ON YOUR BIMINI FRAME!

The Centurion Bimini is designed with materials and finishes that resist the elements. A mild soap and water combination may be used to remove traveling grime or water spots on the metal components. Use only a soft cloth and never use any chemical cleaners. Clean after each use.

For more info on how to clean and care for your Sunbrella Fabric please go to :
http://www.sunbrella.com/en_us/how/cleaning/marine-tops-covers.php

Information: info@roswellmarine.com

If you have any questions please call : 1-321-638-1331



FOLDING YOUR TOWER

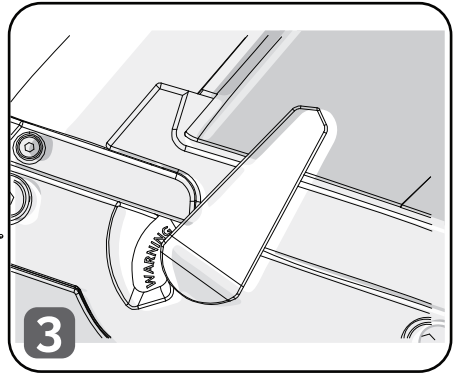
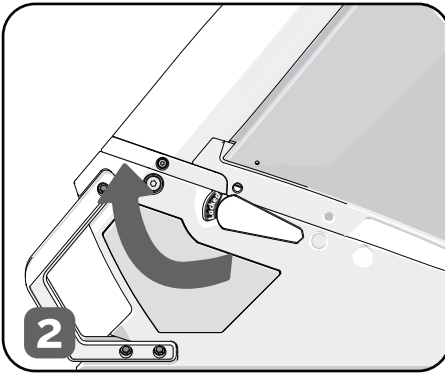
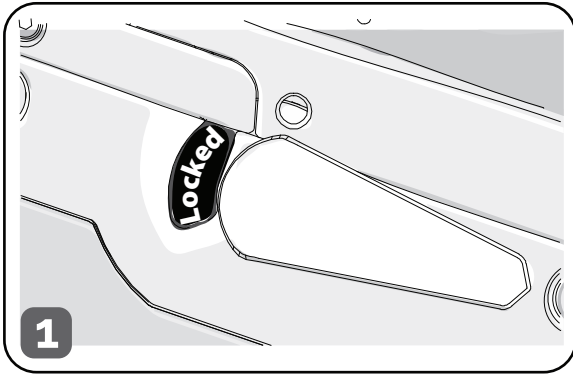

1

Release both cam latches on your tower. Once you have fully disengaged the cam latches there will be a warning sign that will appear fully.



Light off

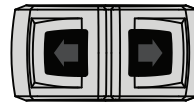

Indicates that your Cam latches are still engaged and there is no power to the actuators.



Light on

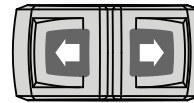

Indicates that the tower is able to fold.

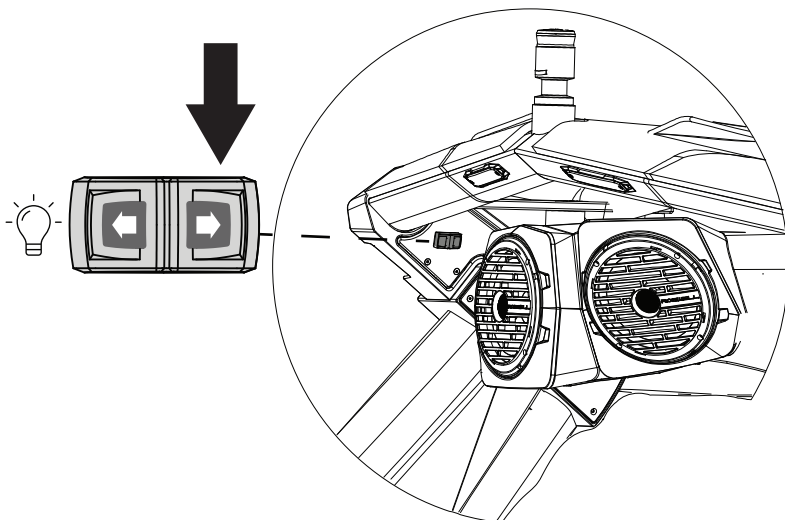

2

First make sure your board rack is swiveled inward. Once your cam latches have been fully disengaged and the switch light has come on, press the front of the switch to lower the tower.

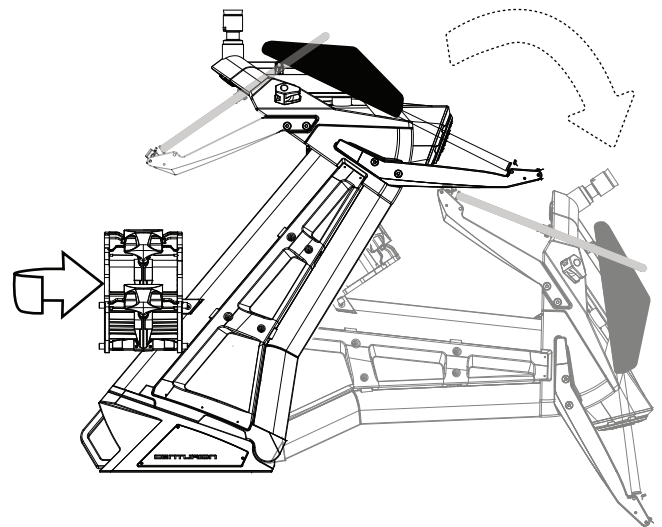

NOTE:

Depending on accessories installed and angle of the boat (ballast bags full/empty, trailer parked on an incline, etc.) You may need to give the tower a slight push to start it folding

UN-FOLDING YOUR TOWER

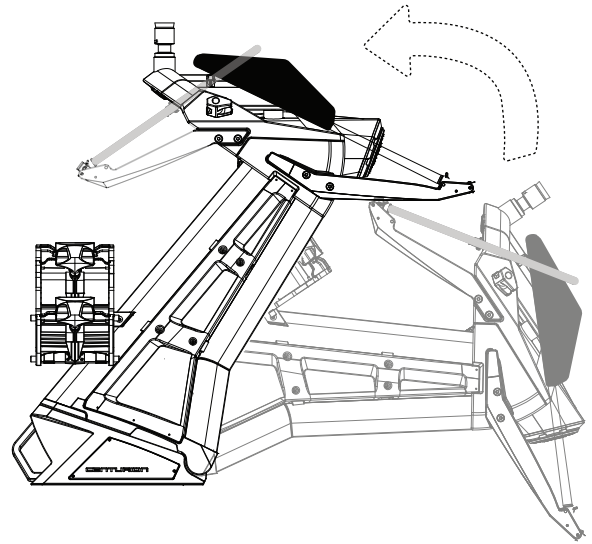
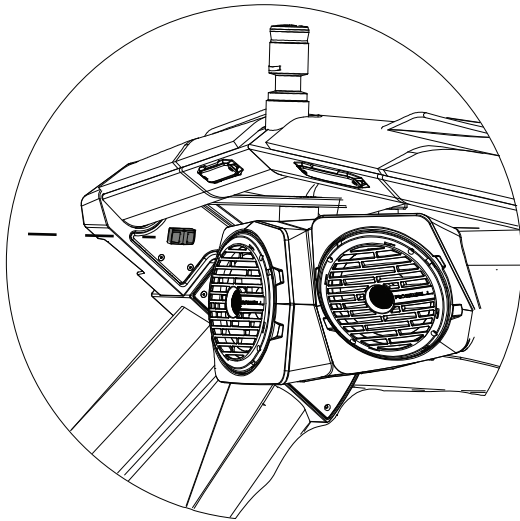
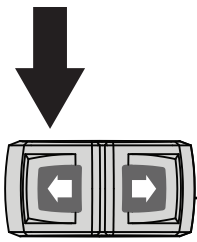

1

To raise the tower ensure that the switch light is on and press the back part of the switch to raise the tower into position. This should come in contact with the bump stops. If this is not the case proceed to pg 27.

! WARNING !

MAKE SURE CAM LATCHES ARE OPEN FOR ACTUATORS TO HAVE POWER ACTIVATION

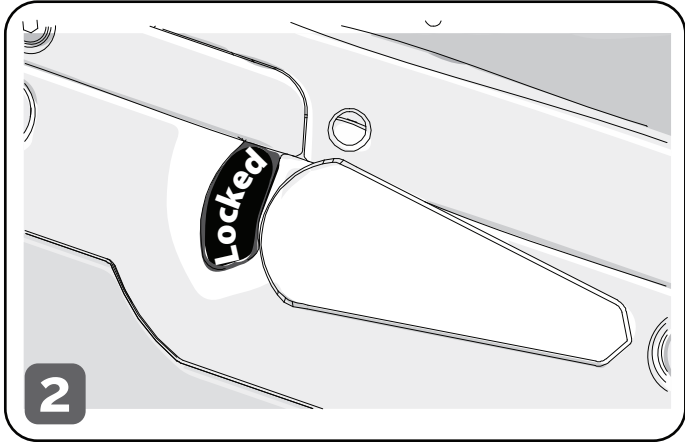
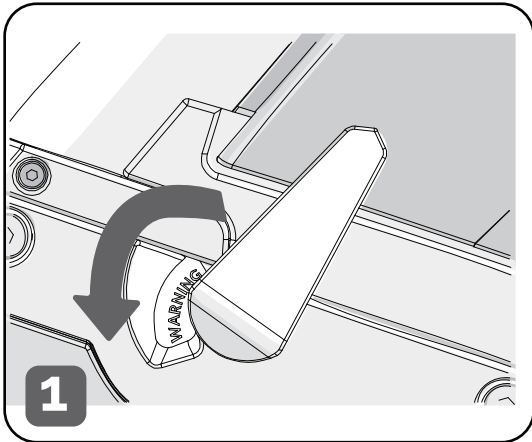

2

Once the tower is fully up and resting on the base plate engage your cam latches. Do so by turning the cam latch in the designated direction and ensure that the locked symbol is fully showing.

! ATTENTION !

BEFORE ANY USE OF THE TOWER ALWAYS CHECK TO MAKE SURE THAT THE CAM LATCHES ARE FULLY ENGAGED AND THE LOCKED SIGN IS FULLY VISIBLE

PLEASE ENSURE ALL OBJECTS AND BODY PARTS ARE CLEAR OF ANY CONTACT POINTS ON TOWER AS IT UN-FOLDS.

Safe Trailing or Storage

Option 1

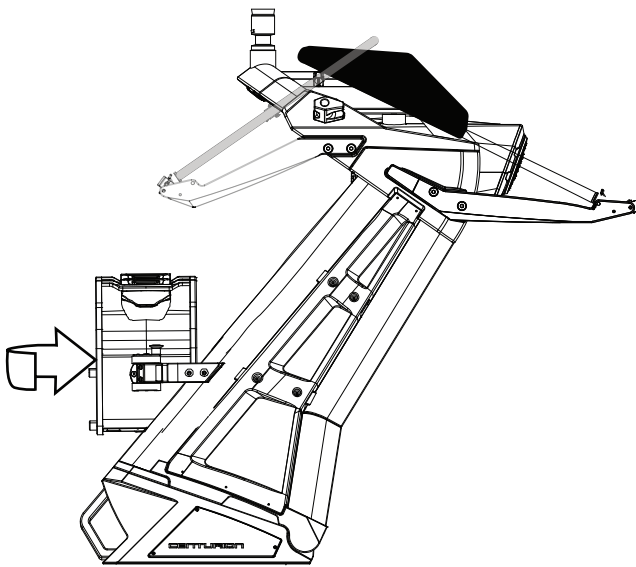

One way of safely traveling with your Drop Zone Auto Tower is in its upright position. Make sure the cam latches are fully locked and the bimini, frame and boot are safely secured around the center section.

NOTE:

Make sure your board racks are swiveled inboard and locked in place.

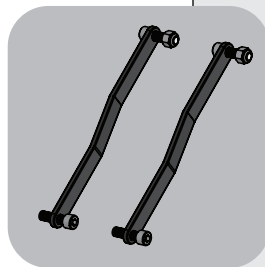

Option 2

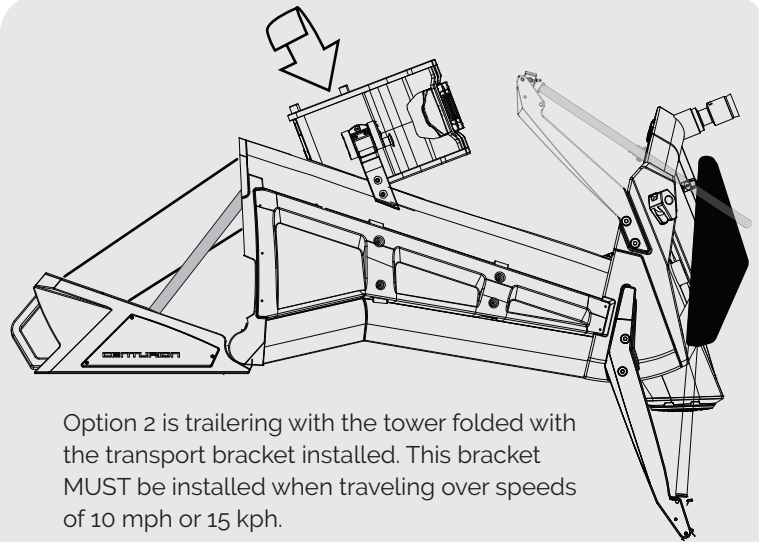

Option 2 is trailing with the tower folded with the transport bracket installed. This bracket **MUST** be installed when traveling over speeds of 10 mph or 15 kph.

NOTE:

Make sure your board racks are swiveled inboard and locked in place.

Bracket Installation (Port)

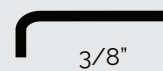
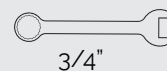
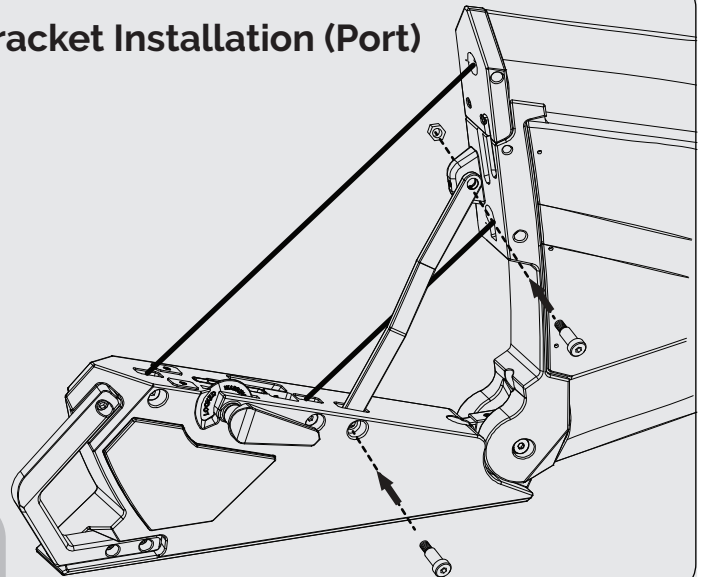

Take a bracket and insert it into the lower bracket mounting location and install the bolt using a 3/8" Allen key. Next swing the top part to come in contact with the upper tower mounting location and install the nut and bold using a 3/8" Allen key and a 3/4" Box End Wrench.

Safe Trailing or Storage

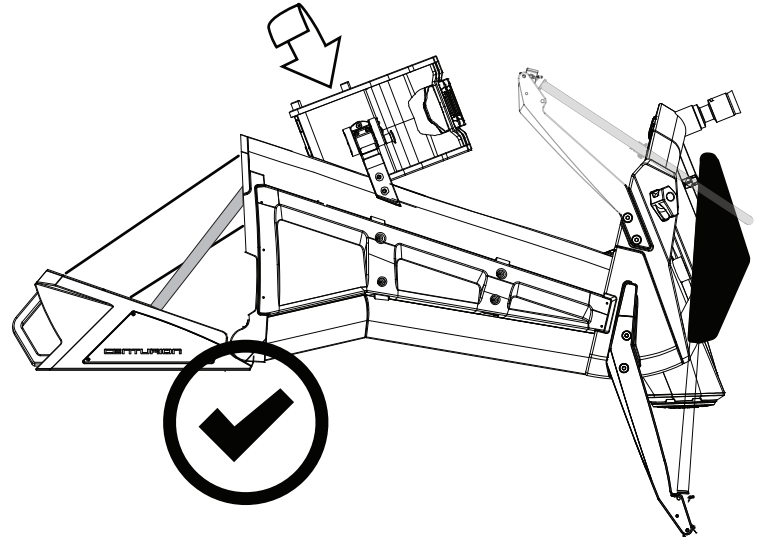
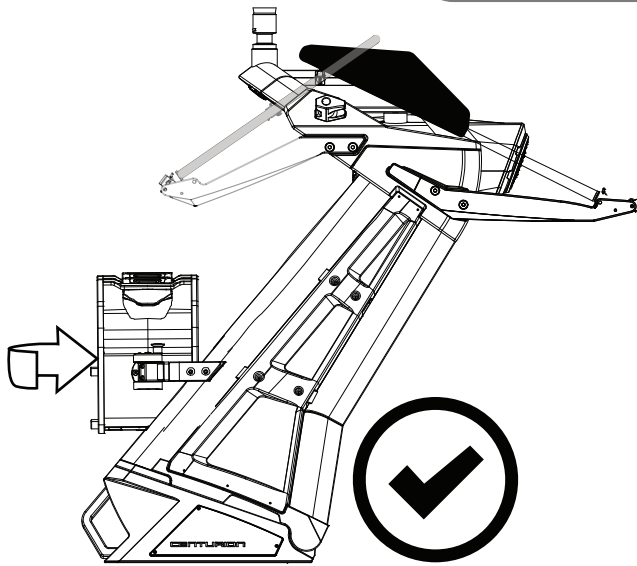

Checklist:

- ✔ Make sure your bimini is booted and strapped to the tower and the bimini frame is locked into place using the quick release pins.
- ✔ Make sure your board racks are swiveled inboard and locked in place
- ✔ Make sure your cam latches are fully engaged.

Checklist:

- ✔ Make sure your bimini is booted and strapped to the tower and the bimini frame is locked into place using the quick release pins.
- ✔ Make sure your board racks are swiveled inboard and locked in place.
- ✔ Once folded make sure the transport bracket is installed for extended trips or storage.

Incorrect Trailing or Storage

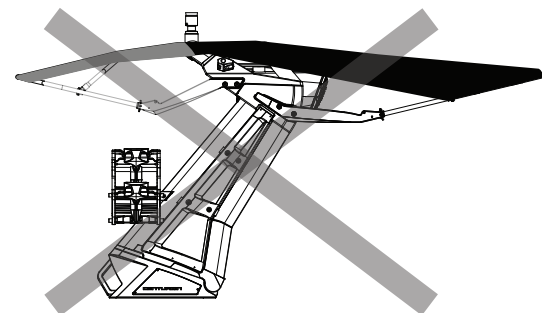
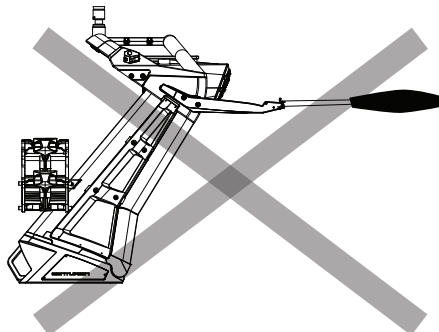
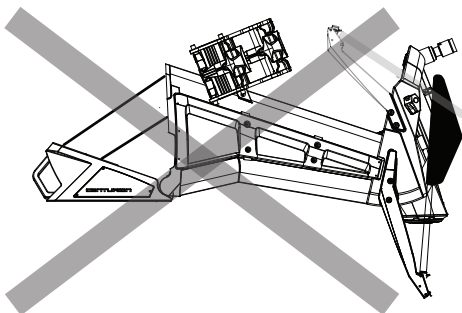

⚠ ATTENTION ⚠

DO NOT TRAILER YOUR BOAT WITH THE BIMINI IN ITS OUTSTRETCHED POSITION. IT NEEDS TO BE SAFELY BOOTED AND STRAPPED TO TOWER.

DO NOT TRAILER ABOVE SPEEDS OF 10MPH OR 15KPH WITHOUT THE SUPPORT BRACKET

Loss of Power

2 Person Job



SCENARIO 1 : Power is lost with your tower in the upright and locked position.

TOOLS NEEDED



1/4" Allen Key



2 inch Low Tack Masking Tape

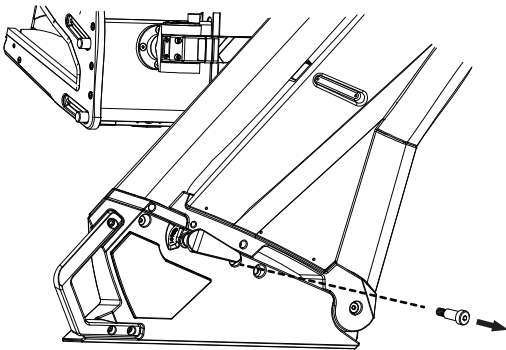

1

Remove the center actuator rod line bolt using a 1/4" Allen key. Remove both sides.

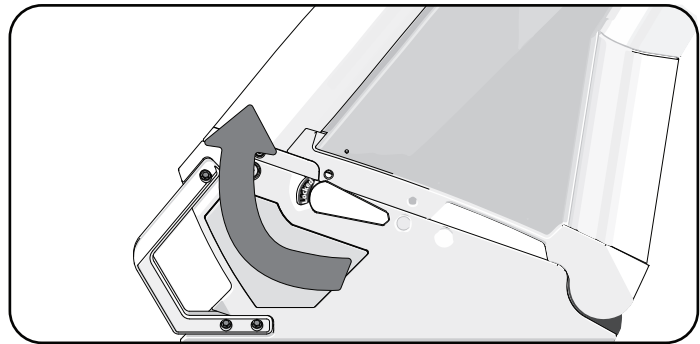

2



! WARNING !

WARNING tower might start to fold due to gravity once both cam latches are unlocked. Be prepared to manually lower the tower. It is heavy, **2 people are recommended**. Unlock both latches.

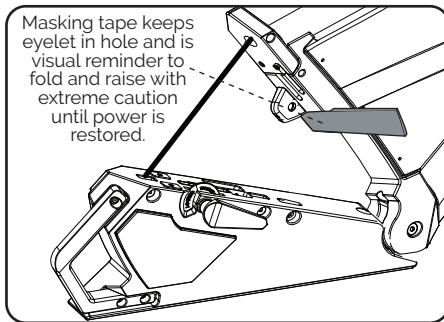
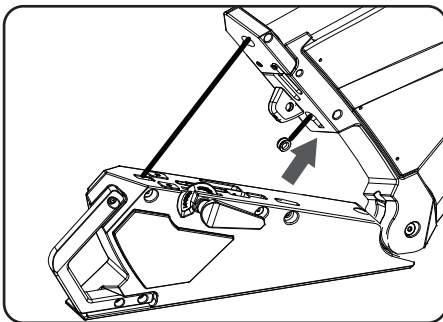

Masking tape keeps eyelet in hole and is visual reminder to fold and raise with extreme caution until power is restored.

3

! WARNING !

Once the tower is folded, stuff the eyelets into the actuator holes to avoid damaging any components. It is recommended that a piece of masking tape be applied over the hole and left hanging to the inside of the boat. This serves as your visual reminder that the tower is in manual mode and requires **EXTREME CAUTION** when raising or folding until power is restored..

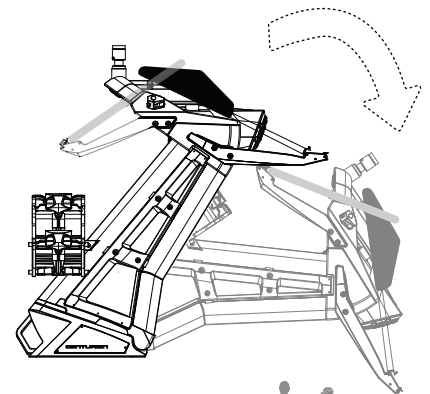

4



Manually fold or raise the tower with extreme caution until the tower has re-gained power.

2 people are recommended. Continue to use the Cam latches to securely lock the tower in the upright position.

Loss of Power

2 Person Job



SCENARIO 2 : Power is lost with your tower in the folded and unlocked position.

TOOLS NEEDED



1/4" Allen Key

2 inch Low Tack Masking Tape

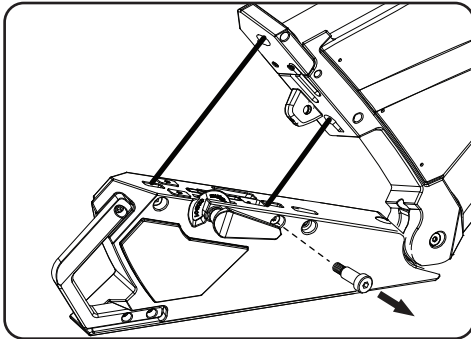
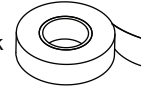

1

Remove the center actuator rod line bolt using a 1/4" Allen key. Remove both sides.

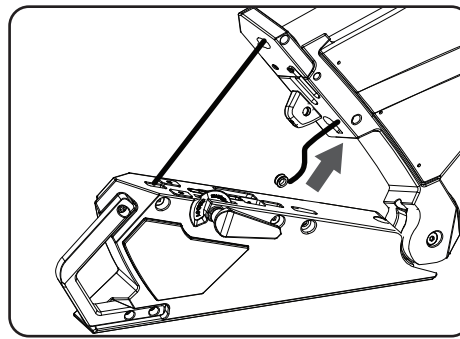

Masking tape keeps eyelet in hole and is visual reminder to fold and raise with extreme caution until power is restored.

2

⚠ WARNING ⚠

Stuff the eyelets and excess robline into the actuator holes to avoid damaging any components.

It is recommended that a piece of masking tape be applied over the hole and left hanging to the inside of the boat. This serves as your visual reminder that the tower is in manual mode and requires **EXTREME CAUTION** when raising or folding until power is restored..

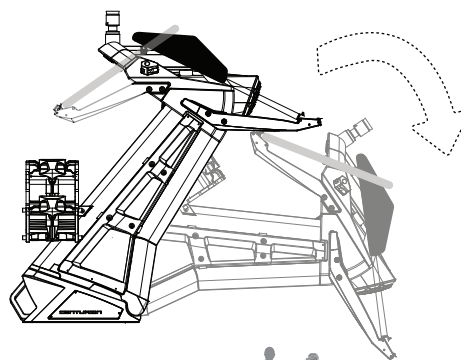

3



Manually fold or raise the tower with extreme caution until the tower has re-gained power.

2 people are recommended.
Continue to use the Cam latches to securely lock the tower in the upright position.

Re-Gained Power

2 Person Job



TOOLS NEEDED

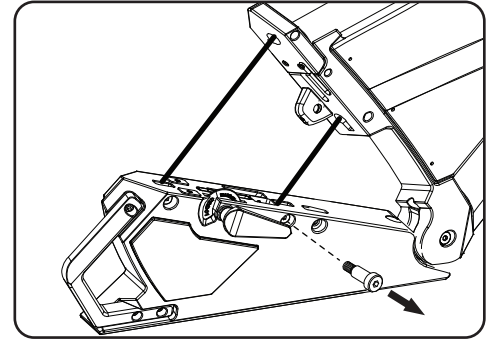
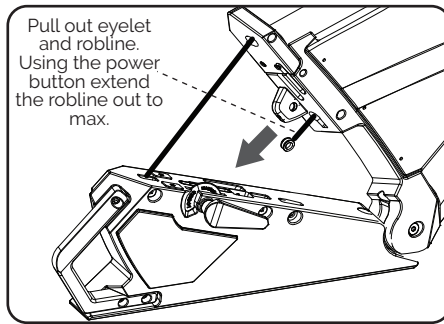
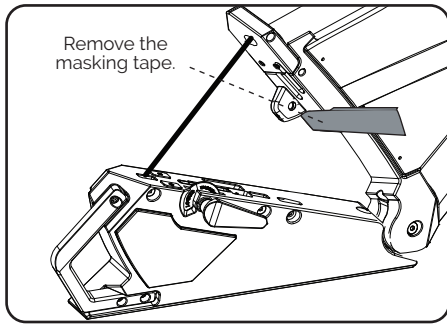

1

2



! WARNING !

Fold the tower carefully, Remove the pieces of masking tape and pull the eyelets and ropline out of the actuator holes
With power restored you can extend out the actuators and increase the length of ropline exposed. This will result in less distance to lift the tower in step 2 and provide the most amount of room to safely work.

2 people are recommended.
One person needs to lift the tower enough to realign the eyelet in the mount holes.
The second person must insert the shoulder bolt through the mount and eyelet and thread tightly. Remember to apply a drop of red thread locker to the bolt before.

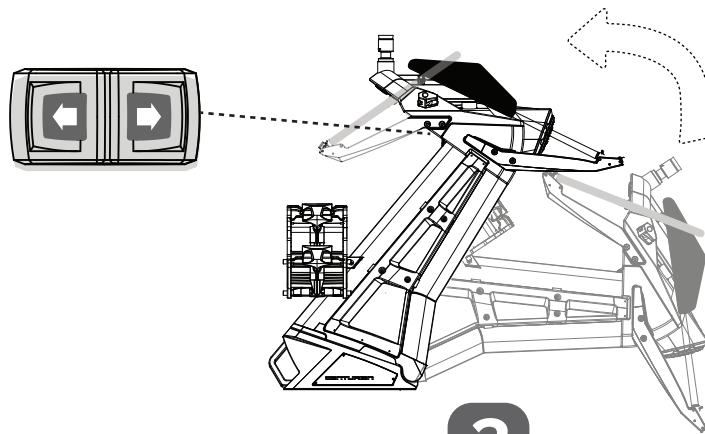

3

Using the power button, raise the tower back into position using the actuators and re-lock the cam latches. Unlock the cam latches again and lower the tower. Raise the tower upright a final time and lock the cam latches. Both actuators are now reset. Continue to use your tower as designed and intended.

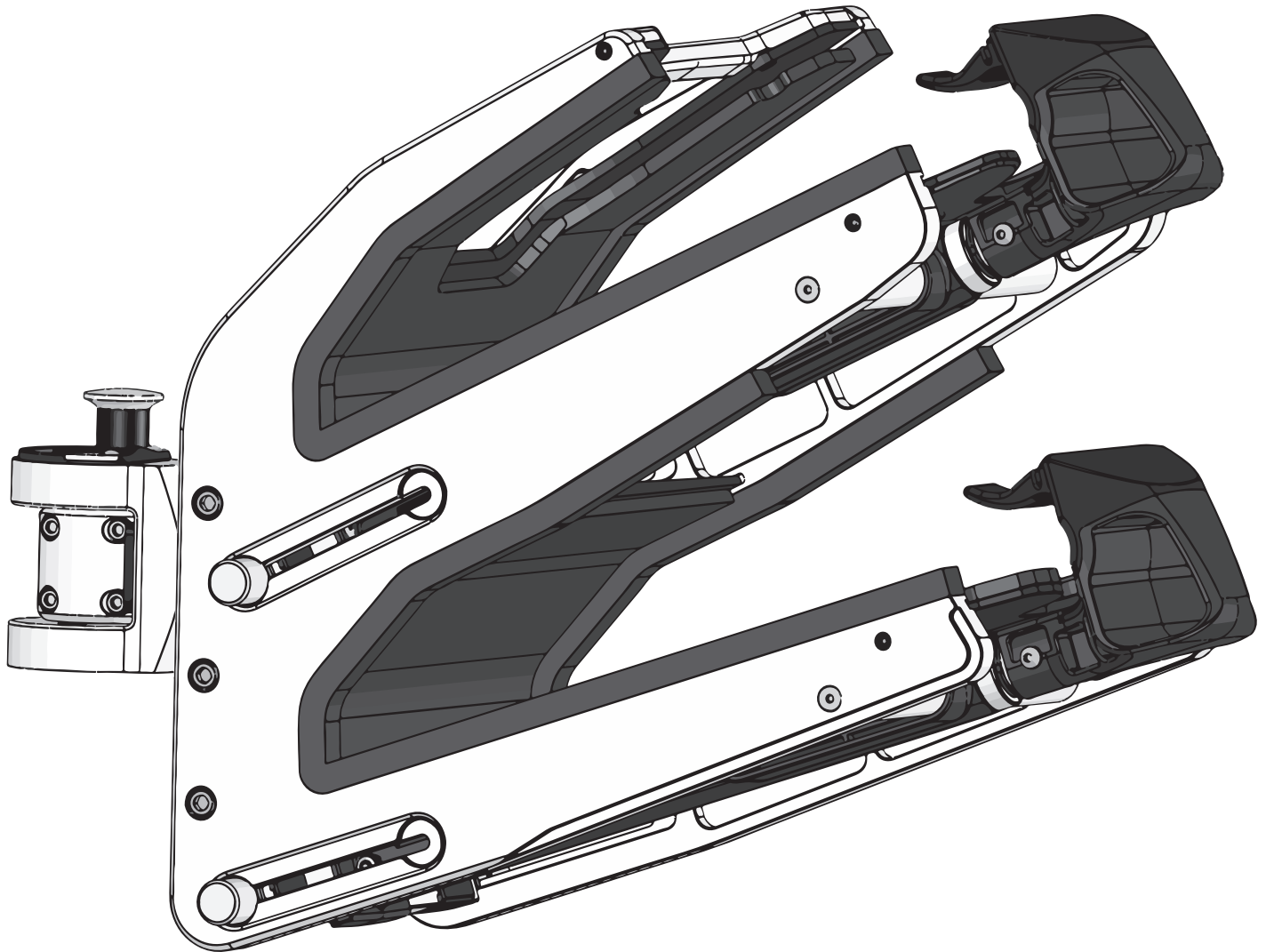

Bombshell Racks and swivels # C913-1904
Rack Adapter # C913-1905

Information: info@roswellmarine.com
Warranty: warranty@roswellmarine

If you have any questions please call : 1-321-638-1331

! ATTENTION !

- Always ensure your boards are securely **fastened** in place by the rack. Give the board a quick tug to check it is secure before setting off.
- Always ensure your swivel is properly **locked** before moving your boat. Give the rack a tug and visually check locking pin to make sure it is secure after you have put the swivel in a new position.
- Never insert boards that are beyond the stated maximums and minimums for the rack:
 - 20" maximum for the narrow board setting and 23" maximum for the wide board setting.
 - 14" minimum for the narrow board setting and 17" minimum for the wide board setting.
- Always swivel your racks inboard when docking and/or trailering your boat.
- Never trailer your boat with boards in the racks. Racks are for on water use only.
- Check all bolts on the rack and swivel for tightness before using your boat. If any bolts are found to be loose remove them, apply red thread lock and re-tighten the bolts.
- The driver should check their lines of sight before operating the boat being sure nothing in the rack blocks their safe view and operation of the boat.
- Be aware of your rope making sure it does not get wrapped around the board rack, the boards, or any other objects.

PACKAGE CONTENTS

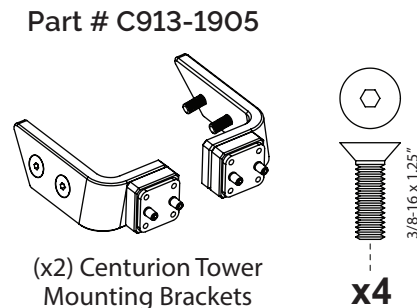
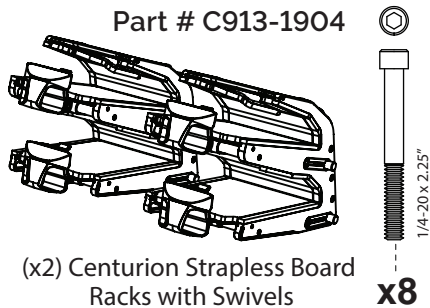

TOOLS NEEDED

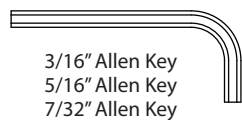

! ATTENTION !

Roswell strongly recommends that a routine inspection of hardware and components be done to ensure proper function and safety and to maximize product life. If bolts are found to be loose, discontinue use until thread lock is re-applied and bolts are re-tightened.

A Centurion Tower

Mount one rack bracket to each side of the tower. Apply red thread lock to the bolts before threading them into place. Note: the brackets are side specific and the orientation of brackets must match the image illustrated below.

Port **Starboard**

x4 Torque bolts to 25ft-lb
7/32" Loctite RED

B Centurion Tower

Mount one rack to each swivel block on either side of your tower using the hardware provided. The racks are not side specific. Apply red thread lock to all 8 bolts first.

x8 Torque bolts to 15ft-lb
3/16" Loctite RED

C Board Width Maximum and Minimum

Your rack is designed to be adjustable to fit just about any size of wakeboard, wakesurfer or wakeskate. There are 2 settings, one for narrower boards, one for wider boards.

In the narrow setting, the max board width should be **no greater than 20"** and **no less than 14"**.

In the wide setting, the max board width should be **no greater than 23"** and **no less than 17"**.

Narrow board setting

Wide board setting

D Board Rack Width Adjustment

Adjust your telescopic arms *one* at a time. To adjust your telescopic arms loosen the knobs on both sides of the rack for the same arm until the knobs are past the counter-bored holes they sit in. At this point you will be able to slide the whole arm assembly up or down to the next position where you will then re-tighten the knobs.

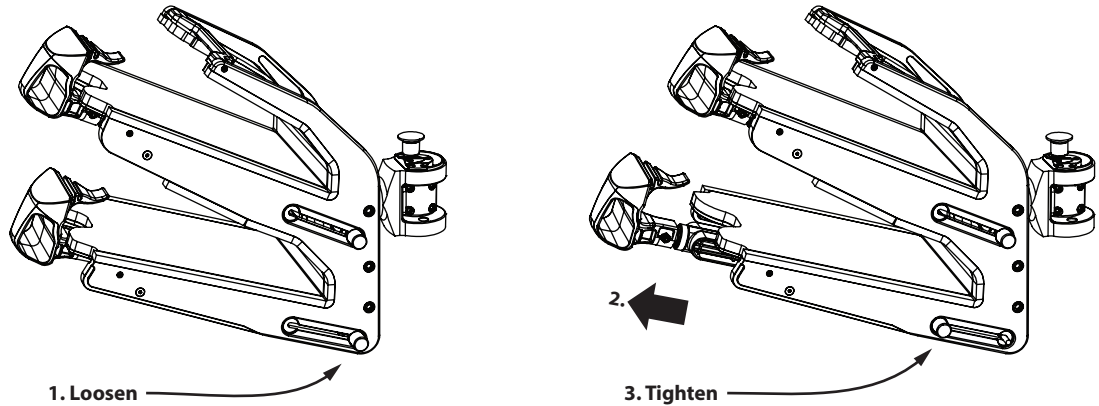

E Inserting Boards

1 : Slide your board into one of the rack slots.

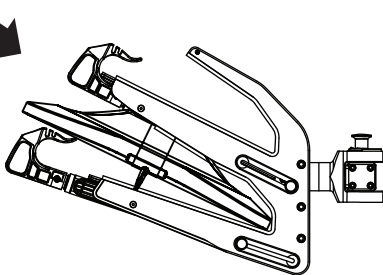

3 : Let the telescopic arm clamp down over your board. To remove a board, repeat steps 1-3 in reverse

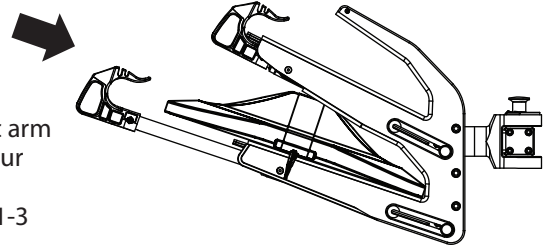

2 : Pull out the telescopic arm and flip your board towards it.

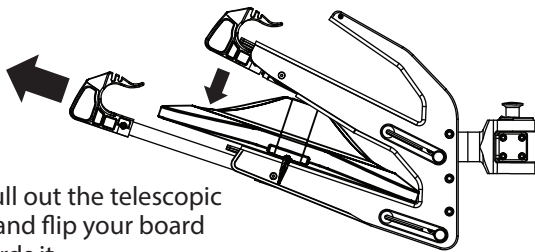

4 : Your board is now clamped

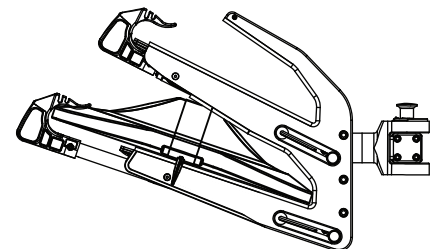

F Swivel Operation

Swivel assemblies must be completely locked to avoid damage to boat or injury to occupants. Proper Swivel operation is crucial to ensure racks do not swing into boat unintentionally. To ensure proper engagement of locking pin be sure to swing racks until they reach a lock position AND compress the rubber bumper at end of travel. Once this is accomplished the locking pin will be drawn down automatically leaving no gap between pin handle and swivel.

How to properly operate the Swivel

1.

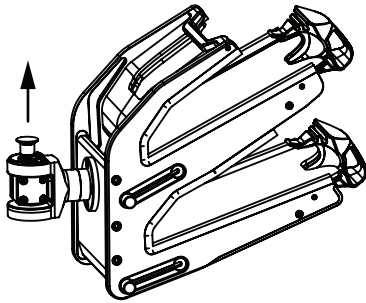

Lift pin to unlock swivel

2.

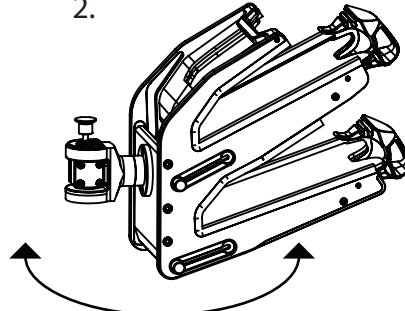

Rotate Rack 180° to second position

3.

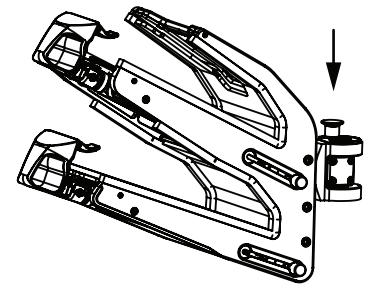

Push rack to compress rubber and the pin will drop in lock hole

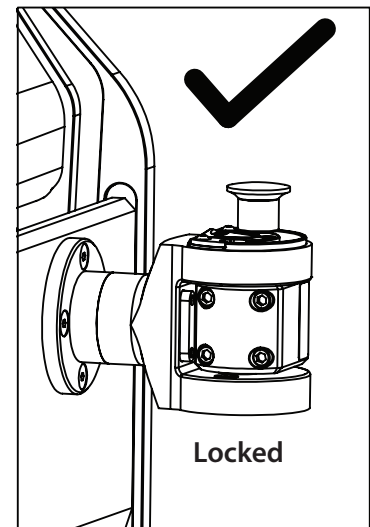
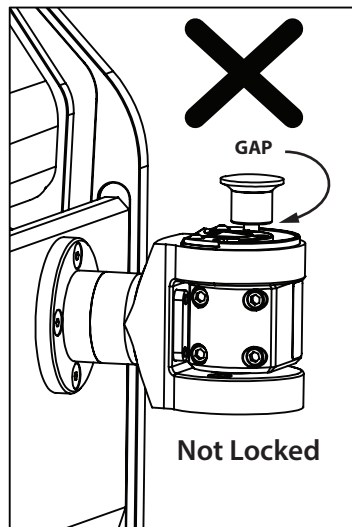
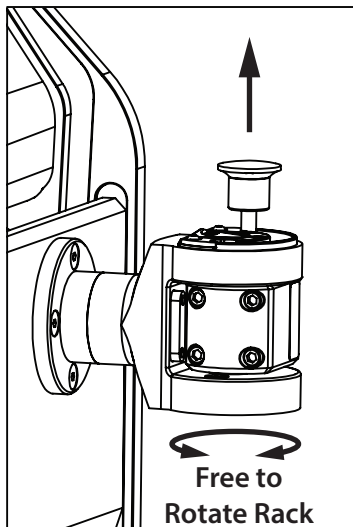

NOTE:

Some parts on the Mag swivel are considered wearable parts. After extended use some parts on the Mag swivel will need replacement. If you feel looseness in your rack the replacement kit will get the swivel working like new. Part # C710-0089

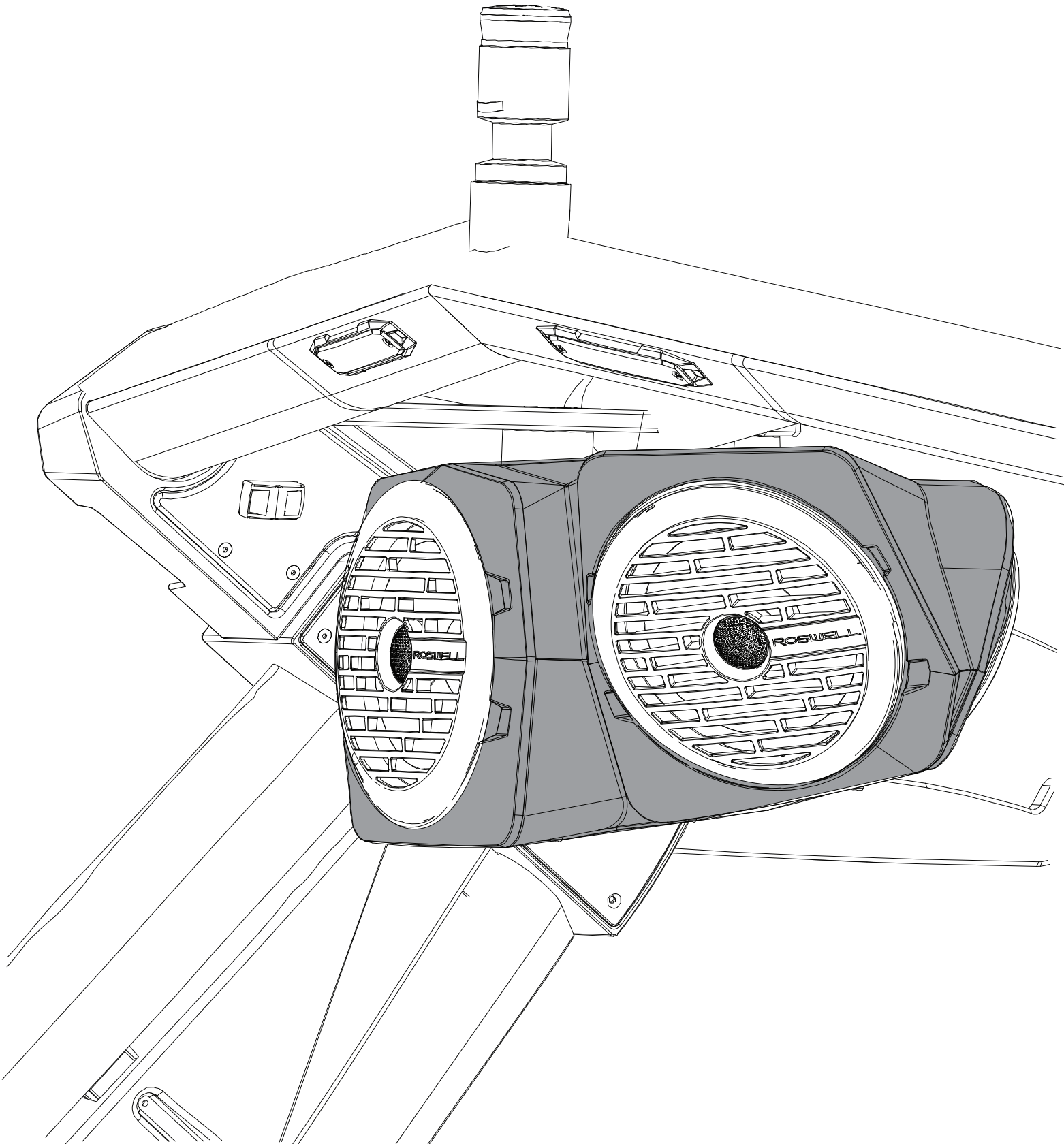

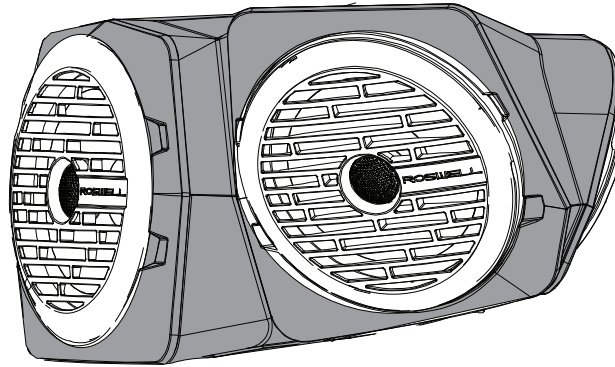

⚠ ATTENTION ⚠

- Bolts and screws tend to rattle loose over time due to the vibrations and shaking that your boat experiences while on the water or in transit. Always check all your speakers are securely fastened by checking speakers bolts for tightness before using your boat. If any bolts are found to be loose remove them, apply red threadlock and re-tighten the bolts.
- Never hang off of the speaker under any circumstance.
- Be mindful of the head clearance to prevent unnecessary head injuries.
- Be aware of your tow rope being sure not to get it wrapped around the speaker or any other objects.
- These speakers are capable of easily producing sound pressure levels (SPL) in excess of 100 dB, even in an open air environment like a boat. Sound pressures at or above these levels can easily cause permanent hearing damage or loss. Be sure to use safe listening practices and protect your ears.
- Users of these speakers should be mindful of their surroundings as sound travels further over water.
- Covering your speakers with something removable such as aftermarket covers during transit or storage can save you a lot of time cleaning and also protect your speakers from damage.

⚠ ATTENTION ⚠

Roswell strongly recommends that a routine inspection of hardware and components be done to ensure proper function and safety and to maximize product life. If bolts are found to be loose, discontinue use until thread lock is re-applied and bolts are re-tightened.

Use & Care

These speakers are built to the highest standards of marine durability. However, they are still a sensitive piece of electronic equipment. When cleaning, avoid hosing down the speakers directly and do not use harsh cleaners on the Coverfires as they could damage the finish. Simply wiping the speaker down with a damp cloth should be sufficient to ensure years of enjoyment.

It is necessary to regularly check the tightness of the bolts securing the Coverfire speaker to your tower. Bolts and screws tend to rattle loose over time due to the vibrations and shaking that your boat experiences while on the water or in transit.

Covering your speakers with something removable like saran wrap or aftermarket fabric covers during transit or storage can save you a lot of time cleaning and also protect your speakers from damage.

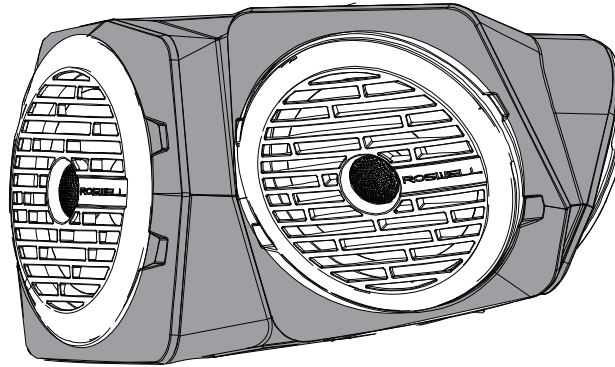

GENERAL SPEAKER CARE & MAINTENANCE

Check all Speaker hardware before every use on the water. We recommend keeping a set of Allen wrenches on your boat for this purpose. Verify that all bolts are tight. Even with threadlocker they may loosen over time.

Watch your head when walking under the tower or getting up from the bench seats. The Coverfire speakers hang low and decrease head clearance.

NEVER USE CLEANERS ON YOUR COVERFIRE SPEAKERS!

The Coverfire Speaker housing has been treated with an automotive paint coating that forms a protective layer. A mild soap and water combination may be used to remove traveling grime or water spots. Clean with each use. Use only a soft cloth and never use any chemical cleaners. Treat as you would your vehicle. Wax to protect finish.

ROSWELL MARINE AUDIO SOUND SYSTEM

BASIC OPERATION

High-powered audio systems provide us with the ultimate in sound quality and an unparalleled listening experience. They also require additional respect and knowledge over a standard stock audio system. Following the information below will ensure you are getting the most enjoyment out of your new Roswell Marine Audio system.

Your Roswell Marine Audio (RMA) Sound system has been optimally tuned from the factory. Making adjustments to the settings in your Clarion CMS2 head unit will alter this tuning and creates potential for damaging your audio system components.

DUAL ZONE VOLUME CONTROL

Your Roswell Marine Audio System is setup into two zones; In-Boat and Tower. Each zones volume can be controlled separately at the turn of a dial.

This control allows you to lower the interior volume to a conversation level while still supplying music to the rider as well as allowing you to turn off only the tower speakers when a rider is not behind the boat.

- The master volume is always controlled by the head unit or one of its remote controls.
- Your dual zone volume control is located on the drivers' console.



**Dual Zone
Volume Control**

BLUETOOTH OPERATION

Your CMS2 Head Unit includes built-in Bluetooth technology that allows you to wirelessly connect Bluetooth devices to this head unit for streaming audio.

Pairing the Bluetooth Device

1. From your Bluetooth enabled device, turn the Bluetooth ON and search for Bluetooth devices.
2. When a list of available Bluetooth devices appear on your Bluetooth device, select "Clarion".
3. "Successful" will appear on the CMS2 display.
4. The unit will automatically enter the BT Audio source and you can now start streaming audio from your Bluetooth enabled device.

Note: If the mobile phone doesn't support SSP (Simple Secure Pairing) Profile, please enter the pass code of "0000" when prompted.

Disconnect / Re-Connect

1. Press the adjust button.
2. Press the up and down buttons until "BT Disconnect" or "Connect" is displayed.
3. Press the play/pause button to confirm the selection.

HEAD UNIT OPERATION

The CMS2 allows the user adjustment of bass, mid, treble, preset EQ and a loudness feature. These features make significant changes in the signal strength and quality produced by the head unit.

Head unit EQ settings are intended to help provide a balanced sound at lower volumes and to compensate for acoustical issues within a listening area. THEY ARE NOT AN EXTRA VOLUME CONTROL. Use of treble, mid, bass and EQ pre-sets creates risk of component damage and should only be used with proper understanding. Damage to speakers resulting from the abuse of these functions will not be covered under warranty.

Use the below information as a guideline if adjusting your audio system.

Note: The Bass, Mid and Treble settings on the CMS2 range from "-7" to "+7", representing a change in signal voltage at these frequencies of +/- 12 dB. This offers a very broad range of control. Misuse of these features can easily distort the audio signal from the head unit and can result in damage to your speakers.

Setting	Frequency	Range
Bass	60 Hz	+/-12dB
Mid	1 kHz	+/-12dB
Treble	10 kHz	+/-12dB

The head unit is optimally tuned from the factory with all EQ settings at "0".

Pre-set EQ

The CMS2 head unit gives its users the option to choose a preset EQ, if so desired. Simply press the [ADJ] button to turn on the equalization function and use the left and right arrows to select between its pre-defined bass and treble curves: Flat->Jazz->Pop->Classic->Rock->News->Urban->Rave->Movie->Techno->User. Simply choose the pre-set EQ setting that suits your listening preferences.

Loudness- RMA recommends you leave this feature off at all times.

This feature is designed to be used when listening to music at low volumes ONLY. This feature will boost the bass and treble ranges to 'enhance low volume listening'. Using the loudness feature at high volumes will damage your speakers.

Head units put out their cleanest signal at lower volumes. You will notice significant signal distortion from the head unit at higher volumes, as well as with higher selections in the on-board EQ's Bass, Mid, and Treble settings. EQ settings above +3 can result in audible distortion and a noticeable drop in sound quality. This signal distortion can easily result in damage to your speakers. Keep all EQ settings at or below the +3 setting.

RMA has factory optimized your audio settings to give you the best sound quality. It is the users' responsibility to use this audio system within the ranges listed above.

NOTE: Tools Required

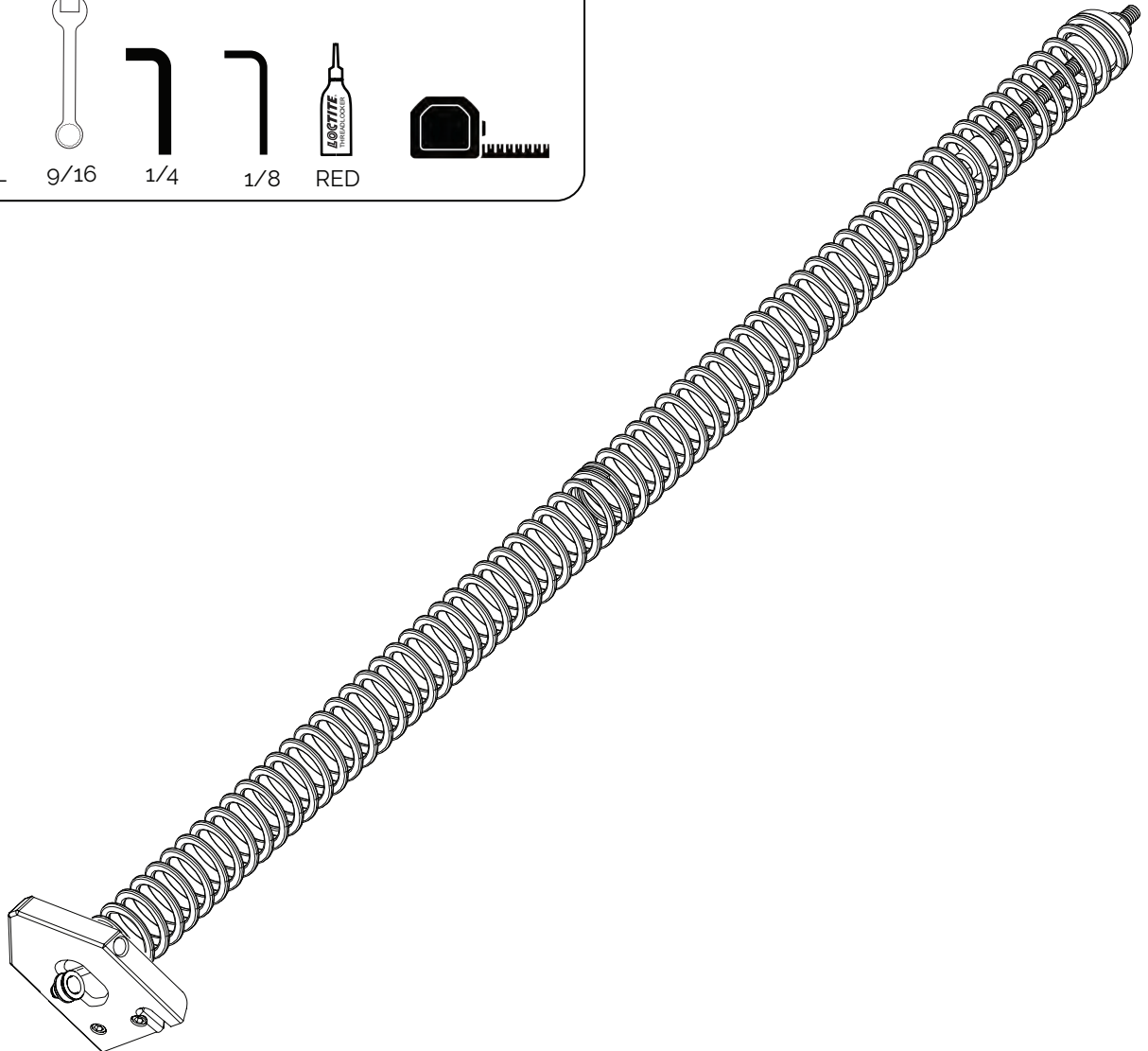
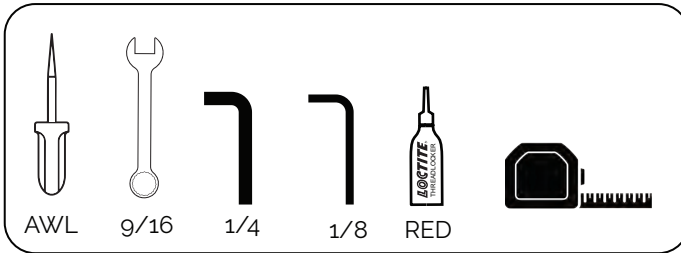

! ATTENTION !

The Drop Zone Auto Tower was designed and set up to a factory weighted tower. You may need to adjust your spring tension if your tower is struggling with the weight of added accessories. As a general guideline, consider adjusting your spring tension if:

The tower takes longer than 28s (on a fully-charged battery) to raise due to added weight.

The tower will not fold due to removal of weight.

Step 1

Remove the weight assist bolt using 1/4" Allen Key.

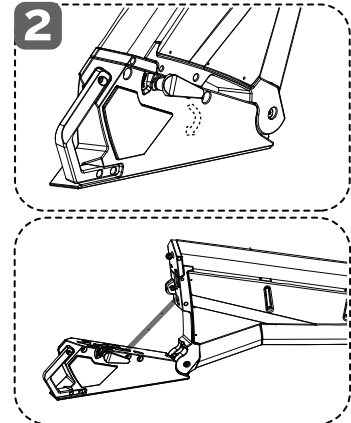
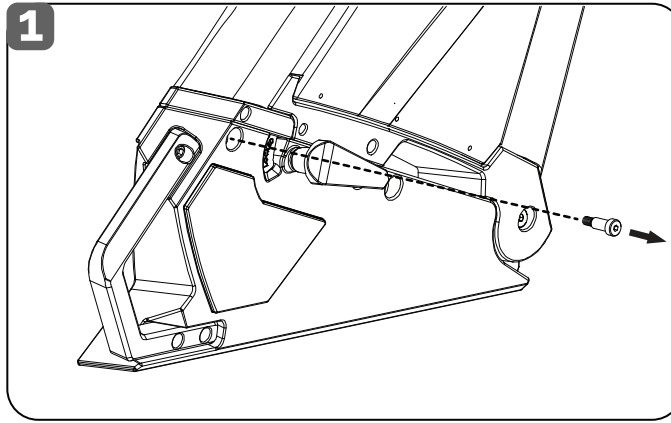

Step 2

Release your cam latches and fold your tower down.

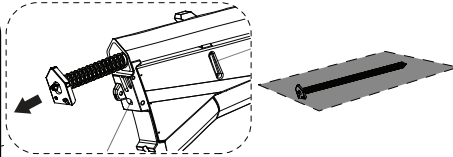
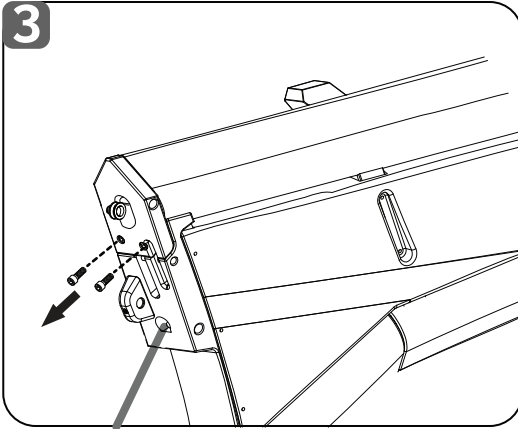

Step 3

Remove the two base cap bolts using a 1/4" Allen Key. Then remove the spring assist system and rest it on a clean soft area.

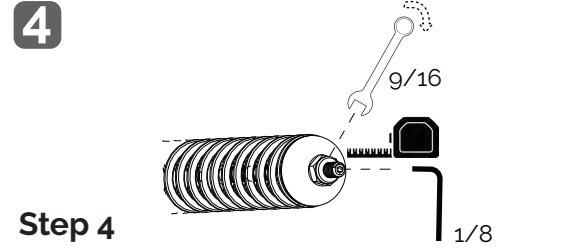

Step 4

Use a 1/18" Allen Key to hold the bolt in place. Use a 9/16" Box End Wrench to tighten or loosen the spring. Take note of the distance of the bolt sticking out from the cap and repeat on the other side.

Step 5

Once you have measured the amount of stem extending out from your weight assist, install it back into the tower. Put Red threadlocker on the bolts and using a 1/4" Allen Key install the bolts.

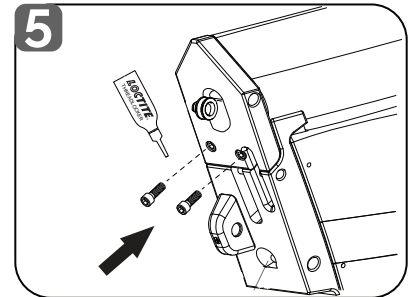
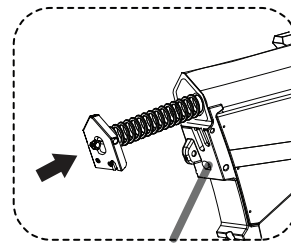

Step 6

Pull the Rob Line out and stick the Awl through it to hold it into place.

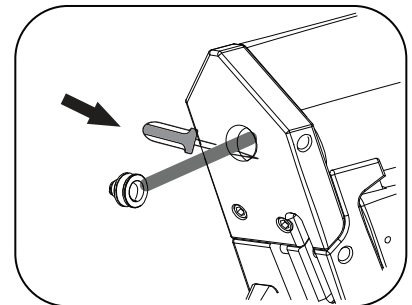
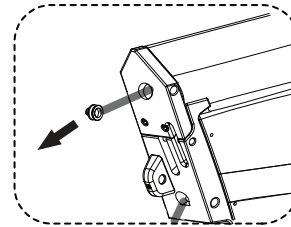

Step 7

Insert the eyelet into its slot and install the bolt with red threadlocker using a 1/4" Allen Key. Once the line has been re-installed remove the Awl and lock your cam latches.

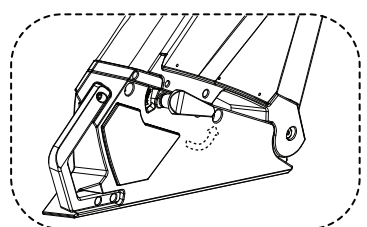
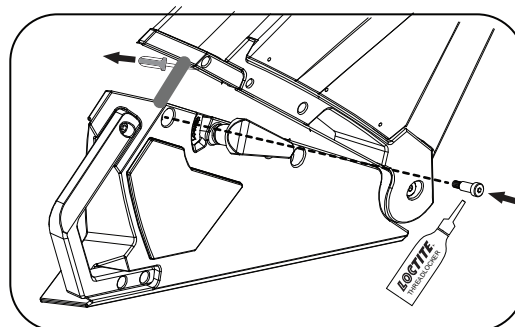

NOTE: Repeat for other side

NOTE: Tools Required

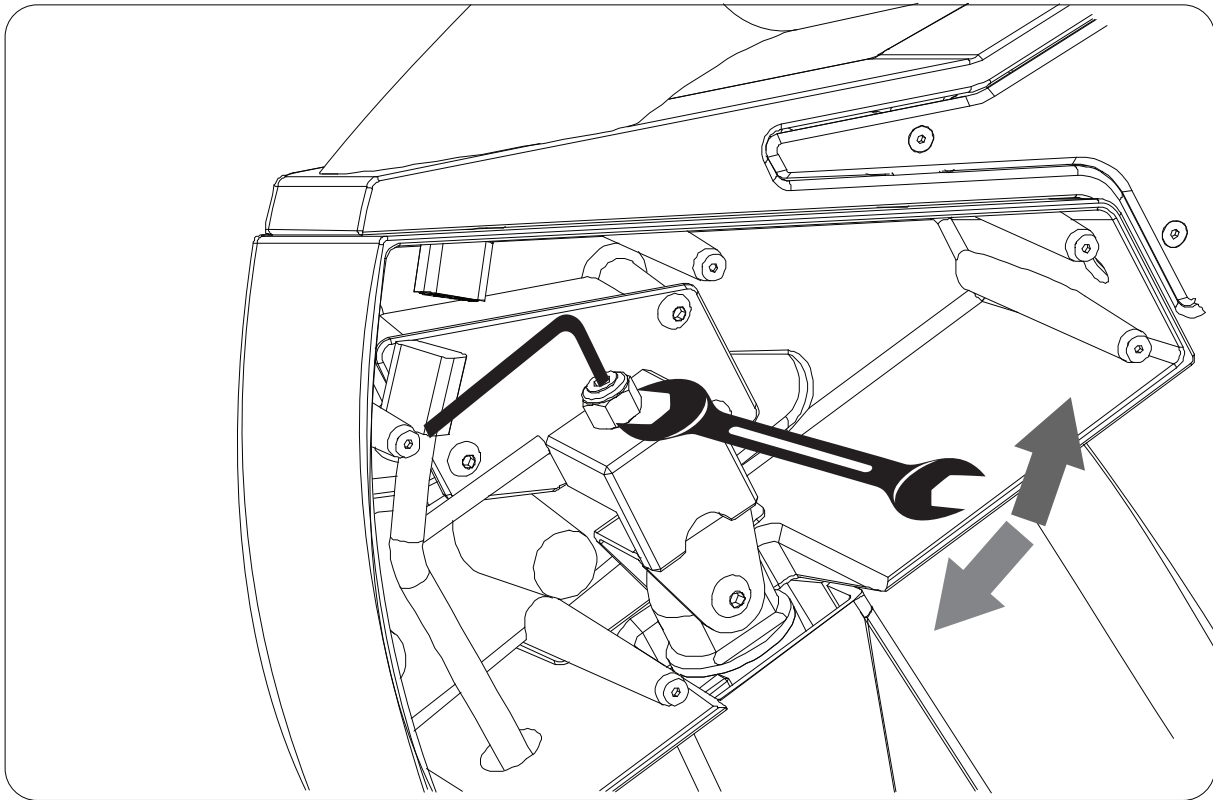
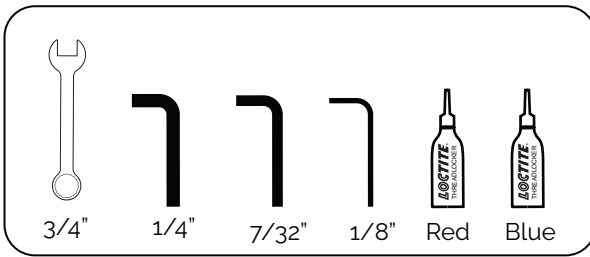

2 Person Job

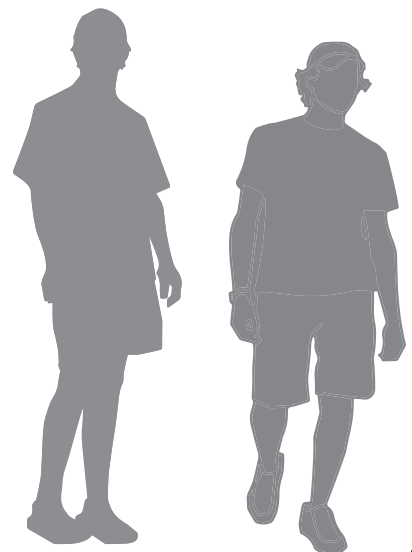

Step 1

Get someone to hold the Coverfire Speaker and remove the five bolts holding the speaker to the tower using a 7/32" Allen Key.

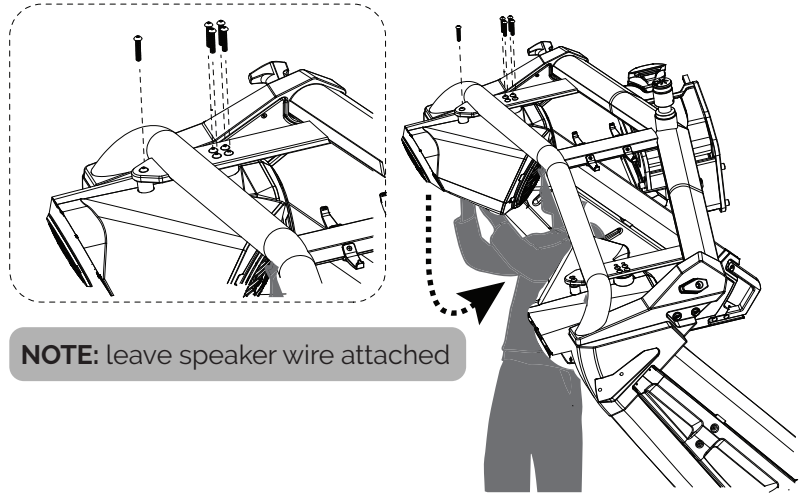

Step 2

Drop the speaker housing down and pull it toward the stern of the boat and hold until re-install of the speaker.

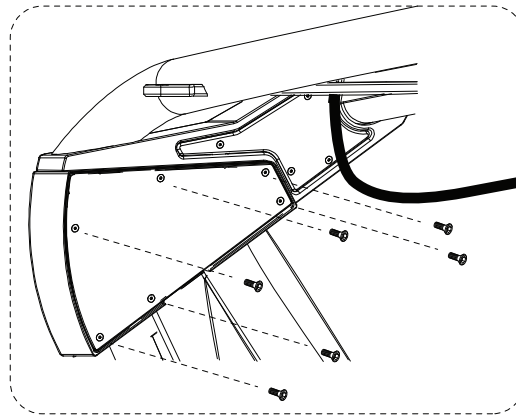

Step 3

Remove the access panel with a 1/8" Allen key.

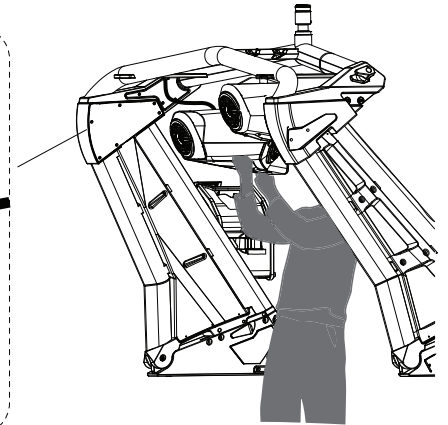

Step 4

To remove the slack in the actuator start by loosening the locknut with a 3/4" box end wrench. Using a 1/4" Allen key, tighten the rob line by rotating the bolt counter clockwise. Once tight, lock the bolt in place with the locknut using the 3/4" box end wench.

Note!
Unlock both cam latches and tighten one side until the tower comes in contact with the rubber bump stops you will have to repeat this for the other side. Do not over tighten as this adds excessive wear to the actuator and Rob line.

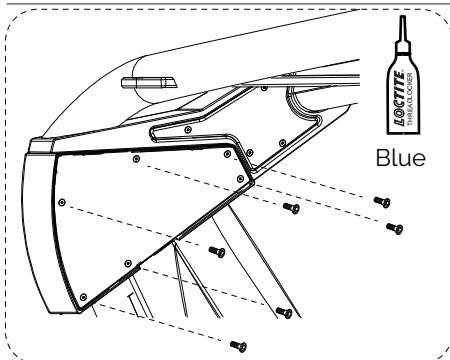
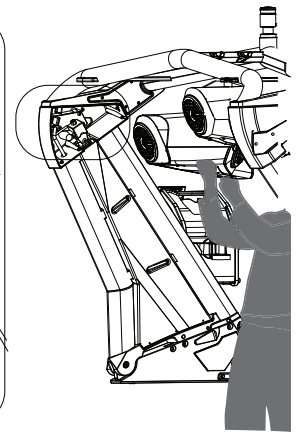
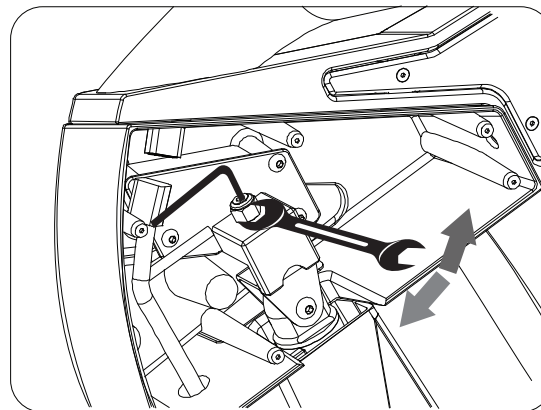

Step 5
Apply Blue threadlocker and install bolts.

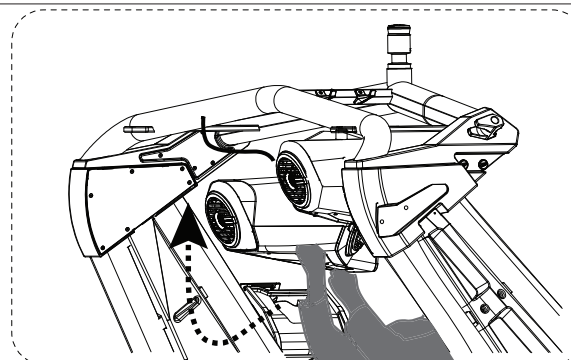

Step 6
Move speaker back into position and feed wiring into the tower.

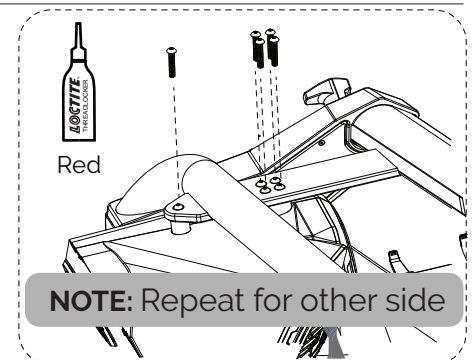

Step 7
Apply Red threadlocker and install bolts.

NOTE: Repeat for other side



CENTURION

DROP ZONE AUTO TOWER WIRING DIAGRAM

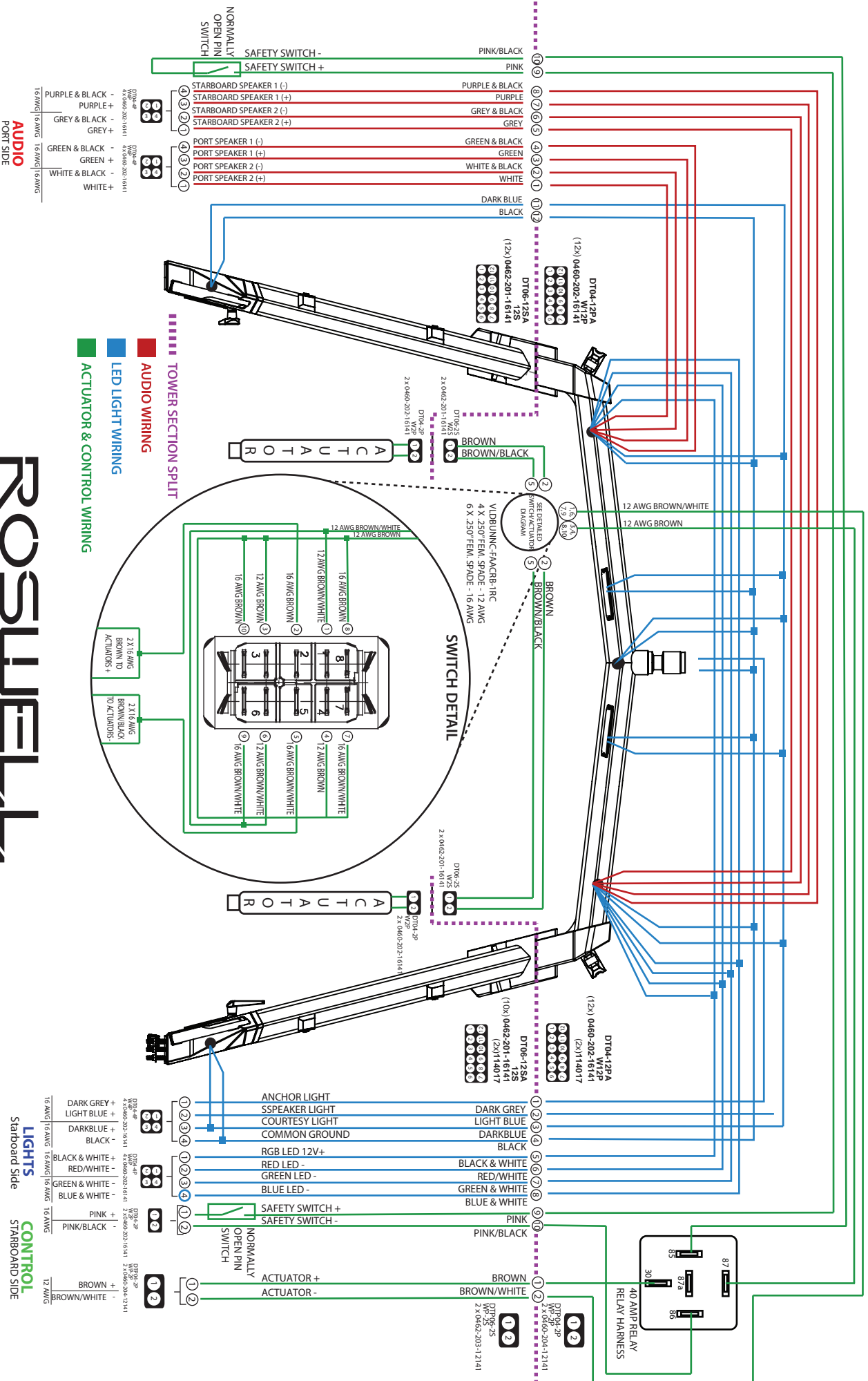

ROSLIFE

REAR VIEW OF TOWER

Centurion Downfire 2 - Wiring Diagram

C913-1906

Port Speaker

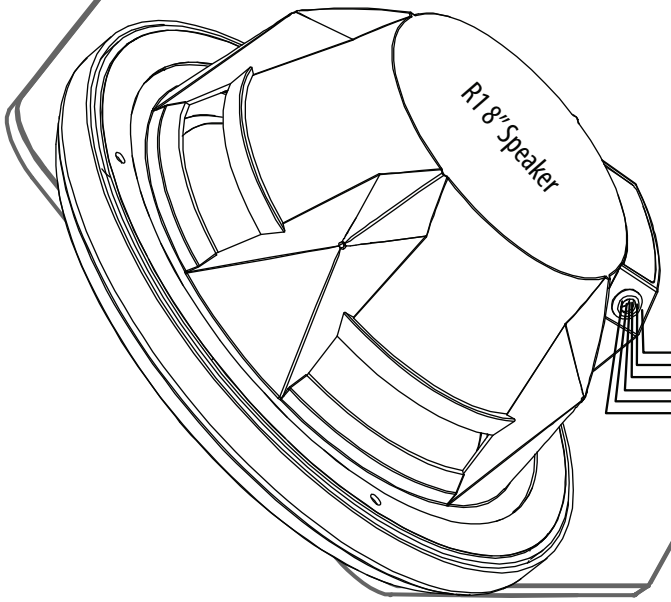
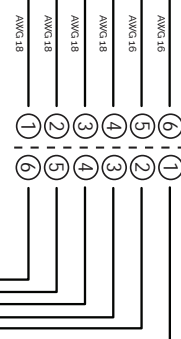
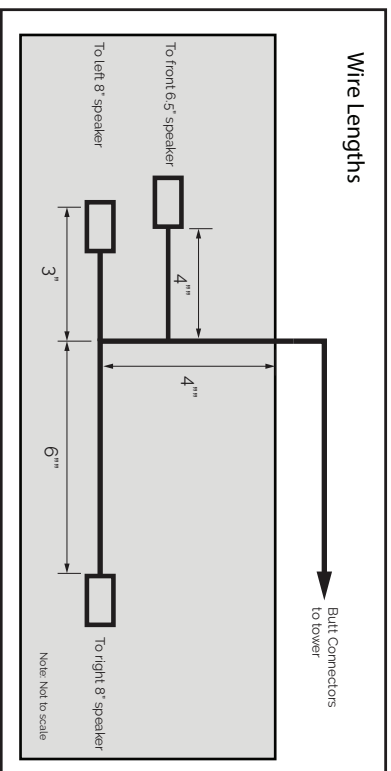
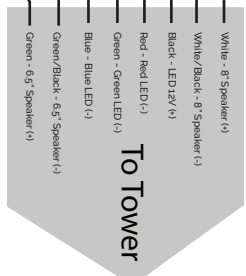
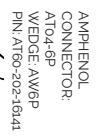
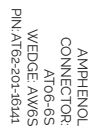
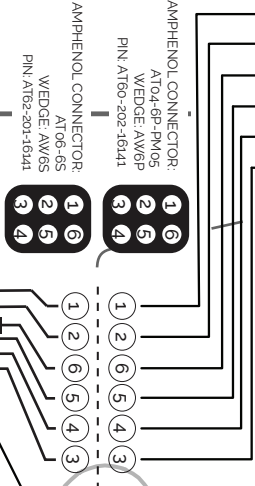
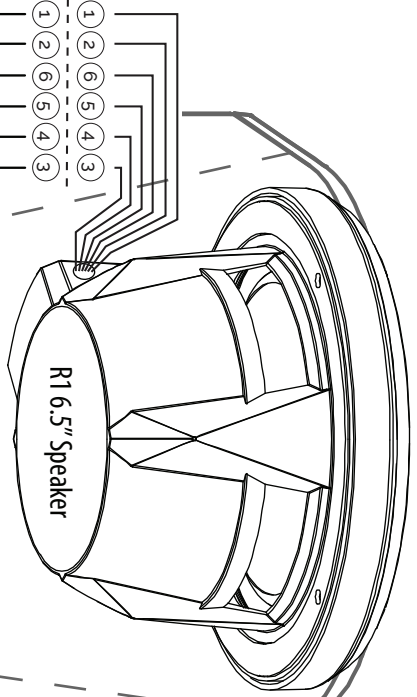
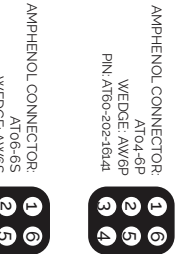

On the Starboard side, the 8" Speakers use Grey & Purple/Black from tower, 6.5" Speakers use Purple & Grey/Black from Tower.