

MOOMBA

Tower &
Accessories
Care / Maintenance / Operation



MOOMBA PRO TOWER

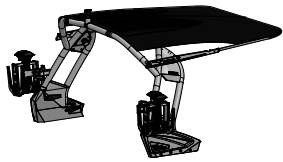
Tower Center Section# C915-119097, C915-119098
Tower Port Side# C915-119096
Tower Starboard Side# C915-119095
Bimini Arms# C915-119152
Bimini# C915-119151
Triton Board Rack# C915-118179
Push Button Swivel & Quick Release# C915-116063
Wake-Surf Rack# C915-116071

Information: info@roswellmarine.com
Warranty: warranty@roswellmarine.com

If you have any question please call : 1-321-638-1331

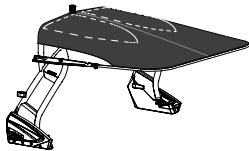


TABLE OF CONTENTS



About your Pro tower _____ **03**

Tower Features _____ **04-05**



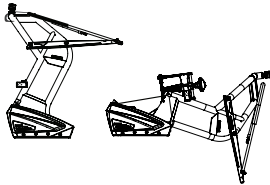
Bimini _____ **06-11**

Installation pg 06-09

Using your Bimini pg 10-11

Trailerling pg 12

Tips and Tricks pg 13-14



Folding Tower _____ **15**

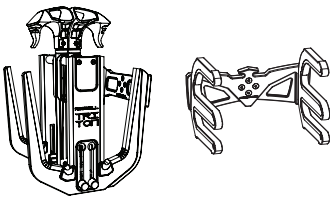
Board Racks _____ **17-24**

Triton Fixed pg 18

Triton Swivel pg 19-21

Wake-Surf Fixed pg 22

Wake-Surf Swivel pg 23-24



Weight Assist Adjustment _____ **25**

Wiring _____ **26-27**

Notes _____ **28**



GENERAL TOWER CARE & MAINTENANCE

This product is to be used for the sole purpose of wakeboarding, wakesurfing, hydrofoiling, and kneeboarding.

The tower is intended to center tow a maximum of two wake boarders at one time and no more than 400lbs (181kg) collectively, side tow a maximum of one wakesurfer at a time 250 lbs (114kg)

Check all tower hardware before every use on the water. We recommend keeping a set of allen wrenches on your boat for this purpose. Verify that all bolts, screws, and nuts are tight. Even with thread-locker they may loosen over time.

Never attach a tow rope to anything other than the tow heads.

Do not use the board racks as entry/exit handles to get in and out of the boat – they are not designed for this purpose.

Never hang from the tower or speakers. Do not climb or sit on the tower.

Be aware of the tow rope at all times. Ensure that it is not attached to anything on the tower other than the tow head, and that the rope is clear of any cleats or objects on the boat before pulling the rider up and out of the water.

Never travel at speeds in excess of 30mph / 48kph (i.e. towing the boat on a trailer) or through extremely rough water with wakeboards, wakesurfers, skis, etc. In the racks.

Never travel at speeds in excess of 30mph / 48kph (i.e. towing the boat on a trailer) or through extremely rough water with the bimini in it's deployed state. ONLY travel with the bimini in it's folded state secured to the tower.

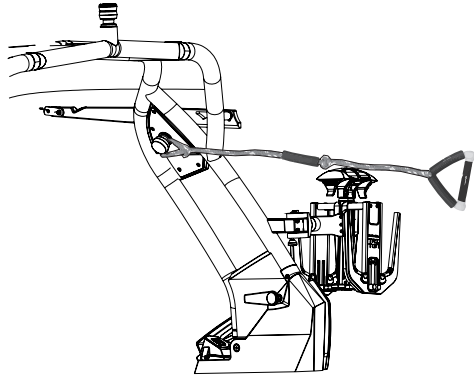
Be cautious when driving your boat on the water or on a trailer if you have board racks. They may decrease your clearance into a garage or slip. Rotate board racks inboard.

Check the clearance between your tower and any overhead obstacles including bridges, canals etc.

NEVER USE CLEANERS ON YOUR TOWER OR ACCESSORIES! Your Roswell tower has been treated with an automotive paint coating that forms a protective layer. A mild soap and water combination may be used to remove traveling grime or water spots. Clean with each use. Use only a soft cloth and never use any chemical cleaners. Treat as you would your vehicle. Wax to protect finish.

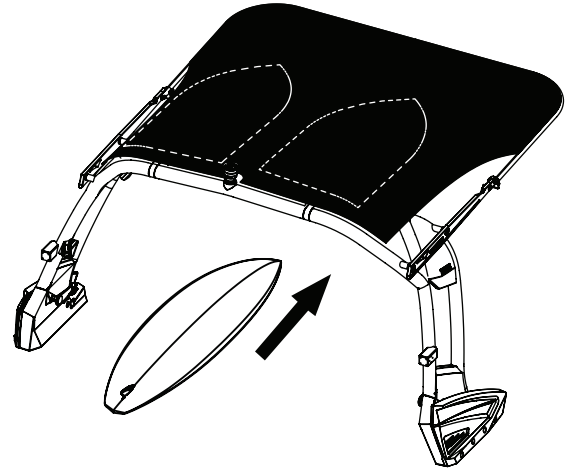
Happy Boating

PRO TOWER FEATURES



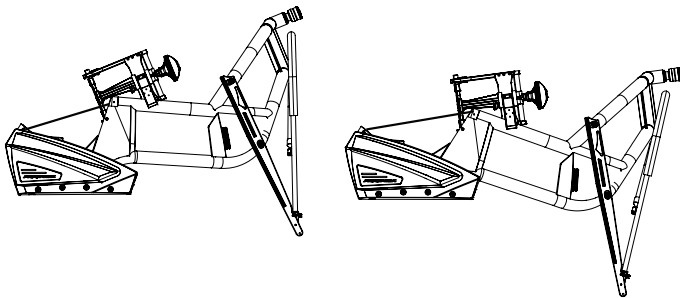
Surf Tow Heads

Why be in the wake when you can be on it. The surf tow heads make it easier to get up without the wash of the wake and allows you to be on the correct side of the wake before you even start. Port & starboard sides available on all towers.



Surf Pockets

Surf pockets are a great place to store extra surfboards. When storing the boards make sure the nose goes in first with the fin pointing to the sky. Lock the boards in place by securing the bungee strap around the fin(s) of the board.



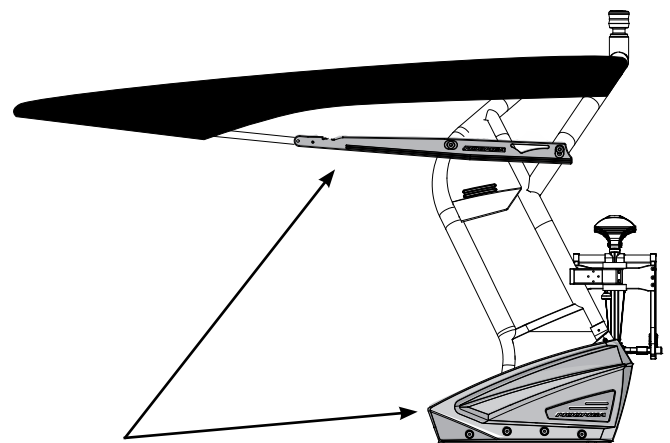
Low clearance while operating.

Fully folded.

2 Folding Positions

The Moomba Pro tower has an additional bumper that allows the tower to fold partially to get under low objects such as bridges when boating.

Note: More information on Page 15



Upgrade Kit

To customize your Moomba Pro tower can have custom painted side plates and bimini arms.

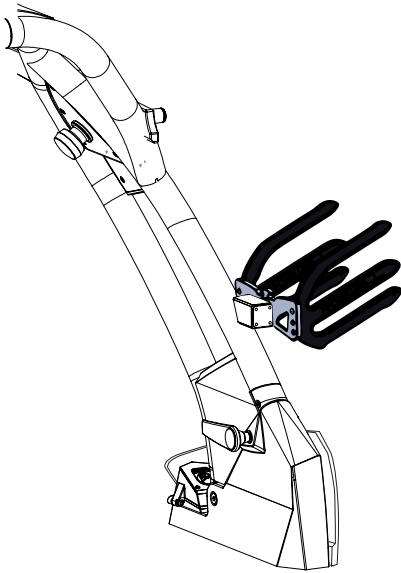
Give yourself a break from sun you can add on a bimini package to the Moomba Pro tower.

PRO TOWER FEATURES

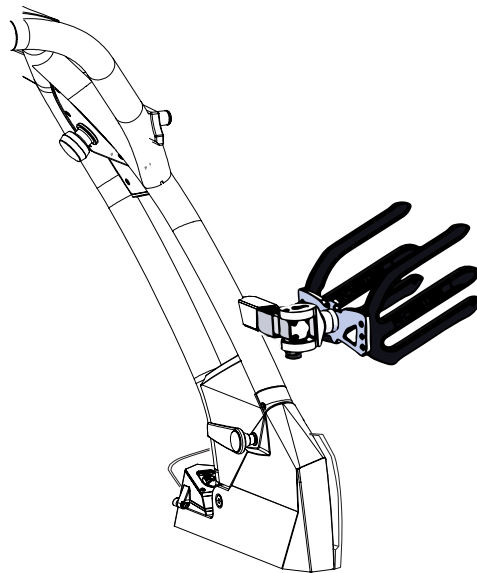
Two Styles of Mounts for Two Styles of Board Racks

Choose between a fixed mount or a swivel mount. The swivel mount also comes with a quick release option for your Wakesurf Rack or your vertical Triton Board Rack.

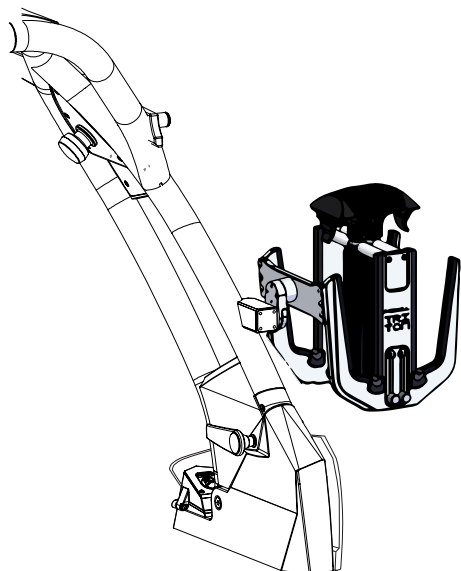
**Fixed Board Rack
C915-116071**



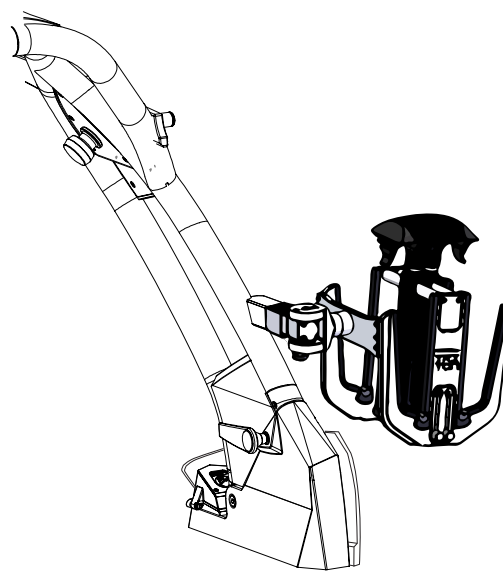
**QR Swivel Board Rack
C915-116063 with
C915-116071**



**Fixed Triton Board Rack
C915-118179**

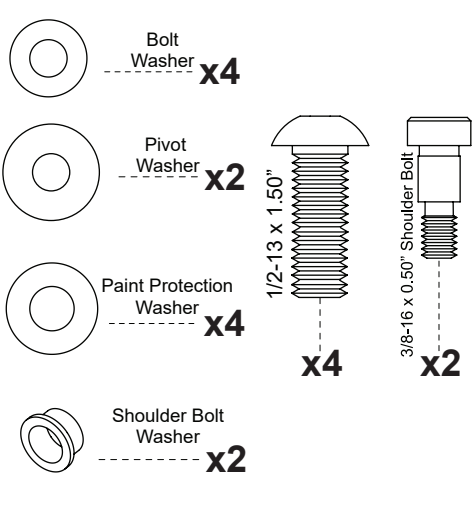
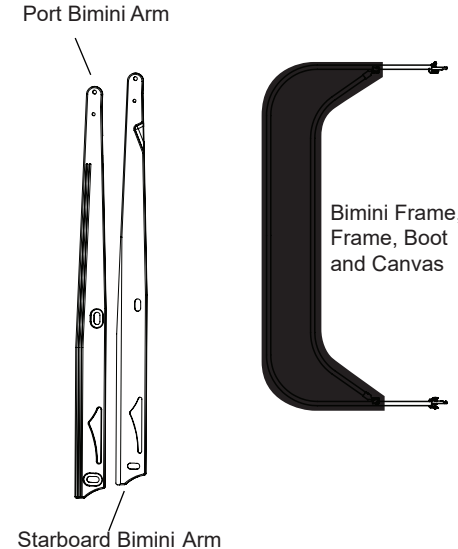
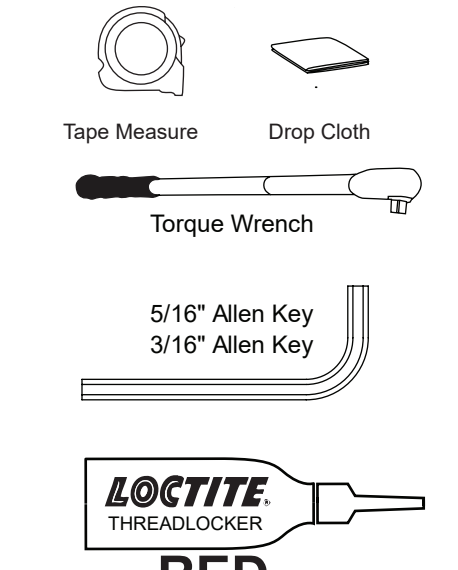


**QR Swivel Triton Board Rack
C915-16063 with
C915-118179**



Note: More information on Page 16

Moomba Pro Bimini Install Instructions

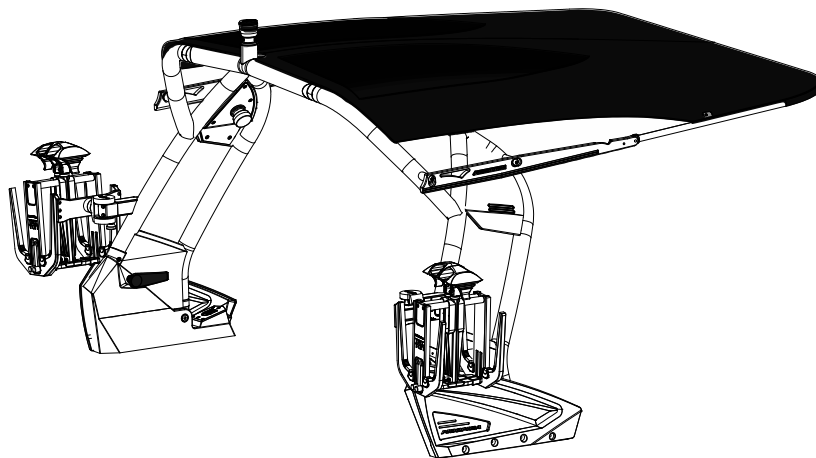
Hardware	Parts	Tools Required
 <p>Bolt Washer x4</p> <p>Pivot Washer x2</p> <p>Paint Protection Washer x4</p> <p>Shoulder Bolt Washer x2</p> <p>1/2-13 x 1.50" x4</p> <p>3/8-16 x 0.50" Shoulder Bolt x2</p>	 <p>Port Bimini Arm</p> <p>Starboard Bimini Arm</p> <p>Bimini Frame, Frame, Boot and Canvas</p>	 <p>Tape Measure</p> <p>Drop Cloth</p> <p>Torque Wrench</p> <p>5/16" Allen Key</p> <p>3/16" Allen Key</p> <p>LOCTITE THREADLOCKER RED</p>

Towers and tower accessories require regular maintenance. Tower hardware and retaining bolts can become loose with normal operation; it is the owner's responsibility to ensure all hardware is kept tight and secure. Corrosion and/or oxidation on coated surfaces as well as on all hardware are specifically excluded from warranty as their care, maintenance, and environments of use cannot be controlled by Roswell Marine. Damage due to misuse or improper care is also excluded from warranty. For full warranty details please contact your local dealer.

Roswell recommends 2 people for installation of the bimini.

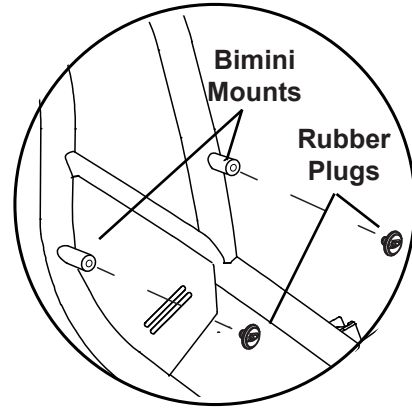
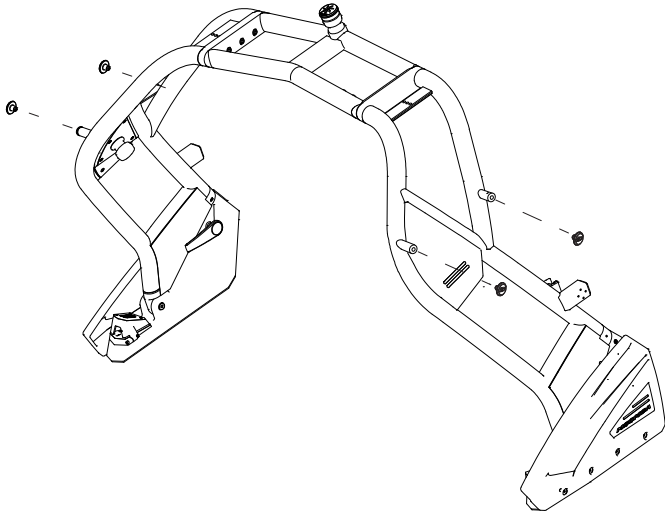
Important

Read & follow these installation instructions carefully. Failure to do so may result in an improper bimini installation. Damage to parts due to improper bimini installation is not covered under warranty.



Moomba Pro

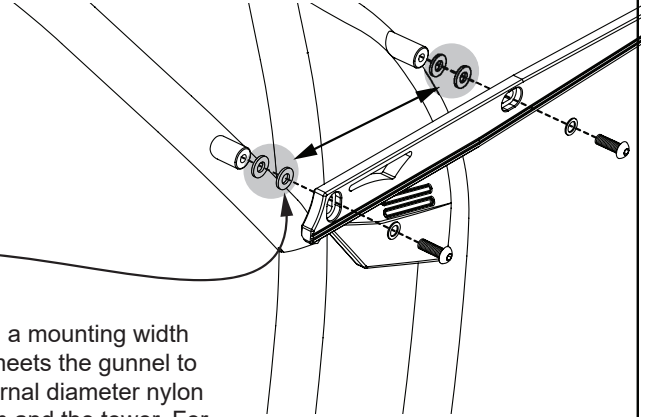
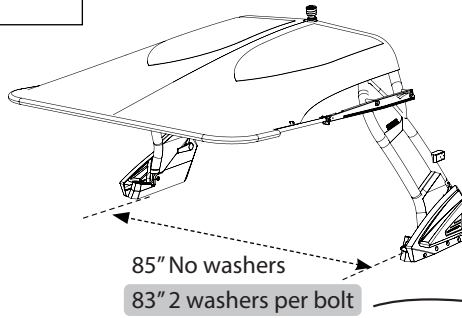
A Preparing your tower



Remove the 4 rubber plugs from the bimini mounts on your tower. These are press fit into the bimini mounts and do not require any tools to remove.

B Installing Bimini Arms

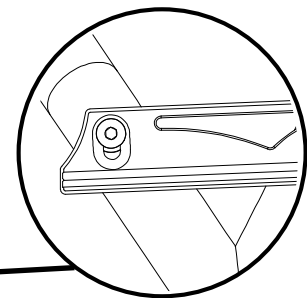
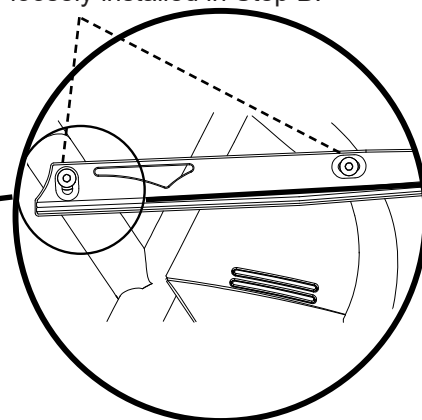
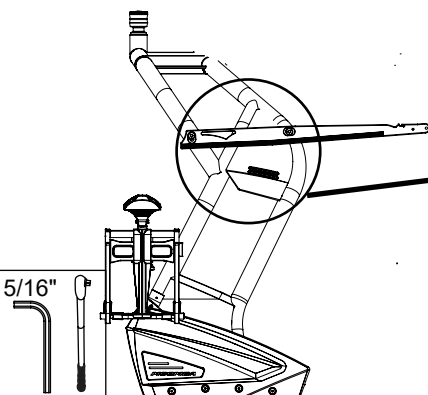
-  x4
-  x4
-  x4



First assemble the bimini arms to the tower. For towers with a mounting width of 83" (measured from the inside edge of the foot where it meets the gunnel to the opposite inside edge) use two of the 1/8" thick 0.54" internal diameter nylon washers behind each mounting hole between the bimini arm and the tower. For towers with an 85" width do not use any washers. Apply red threadlock to each bolt before threading them in. Do not tighten the bolts all the way yet.

C Tighten Bimini Arm Bolts

Position arms as illustrated, then tighten down the bimini arm bolts that were loosely installed in Step B.



****IMPORTANT****

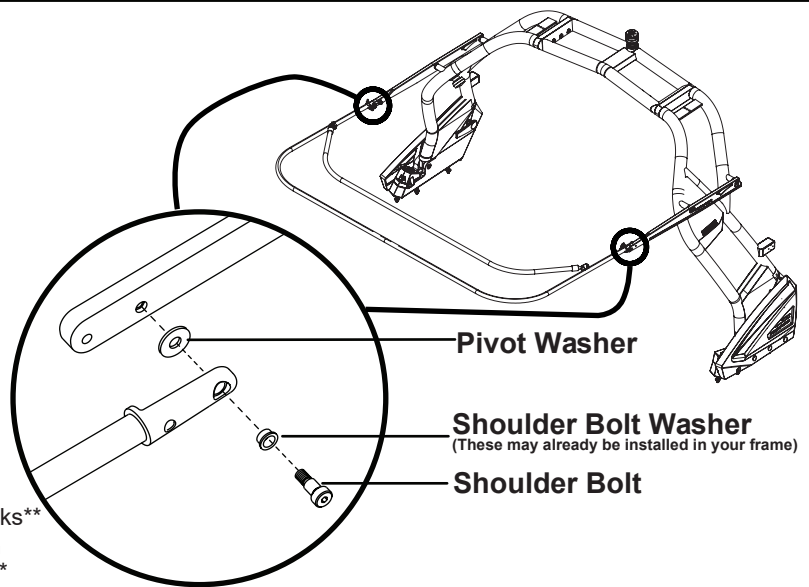
Tighten the Rear Bolts at the top of the slots as illustrated.

Torque bolts to 40ft.lbs

D Bimini Frame Assembly

****This step requires 2 people****

Remove the plastic wrapping from your bimini frame. Grab the 2 shoulder bolts, 2 pivot washers, and 2 shoulder bolt washers from your bimini box. Apply red Loctite to the 2 bolts. Attach the bimini frame to the bimini arms as illustrated. Make sure the pivot washers are sandwiched between the bimini arms and the bimini frame and that the shoulder bolt washers are under the heads of the shoulder bolts.



Pivot Washer

Shoulder Bolt Washer
(These may already be installed in your frame)

Shoulder Bolt



x2



x2



x2

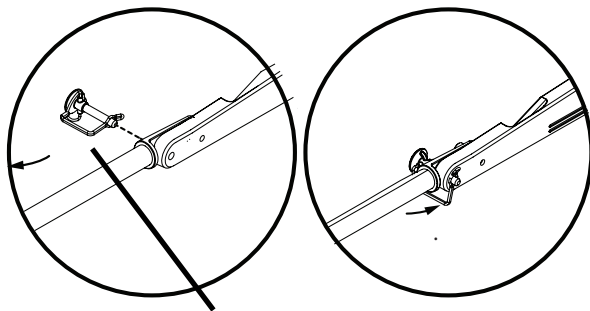


3/16" ****Refer to page 15 for Alignment Tips & Tricks****
****To avoid installing the frame upside down make sure the middle bow rotates upward****

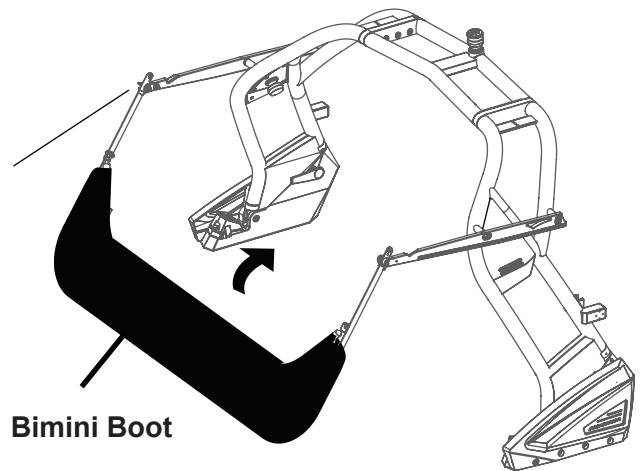
Torque bolts to 15ft.lbs

E Bimini Boot Removal

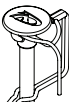
Unzip the bimini boot from the bimini frame. Unroll your fabric and middle bow. Rotate the frame upwards and insert the quick release pins through the arms and bimini frame.



Folding Quick Release Pin

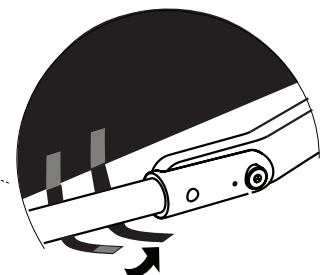
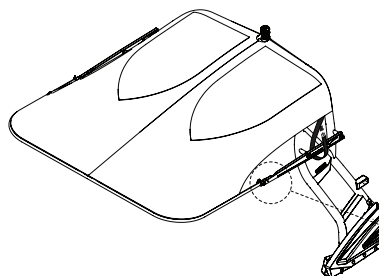
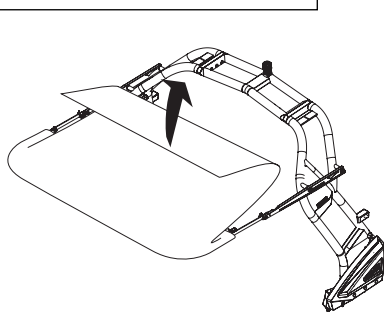


Bimini Boot



x2

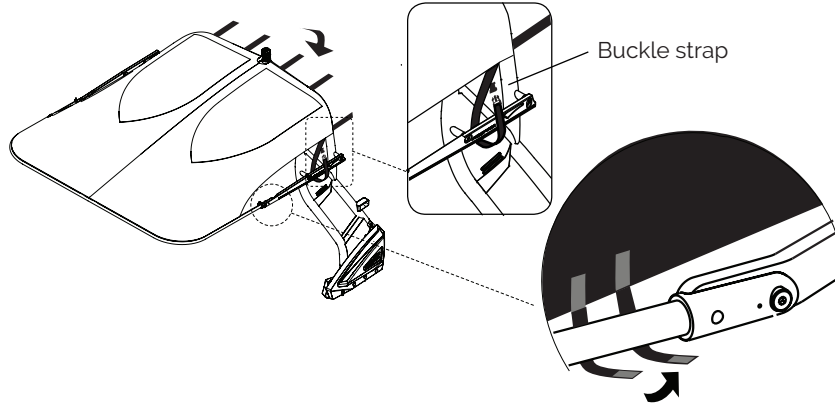
F Velcro Straps



Adjust and secure the 2 velcro straps located on either side of the bimini canvas to the bimini frame as illustrated also attach the rear buckle strap.

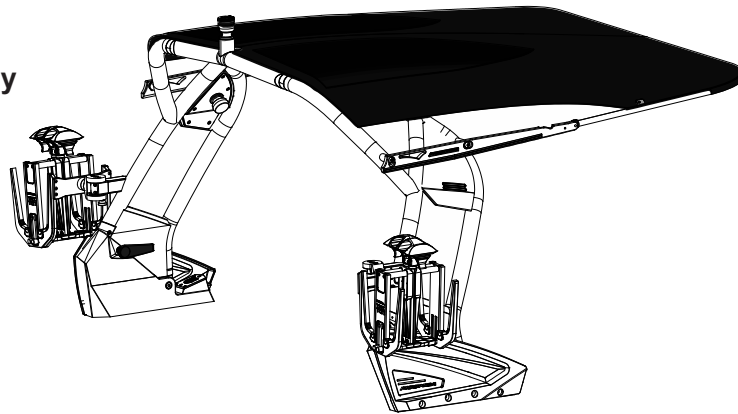
G Final Velcro

Attach all 8 velcro straps on the rear of the bimini to the rear tower tube and the 2 buckle straps to the rear bimini mount. After attaching all straps, adjust and secure them until the bimini canvas fits tight. Your bimini installation is now complete!

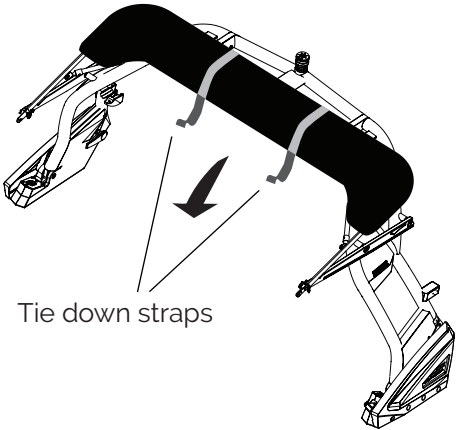
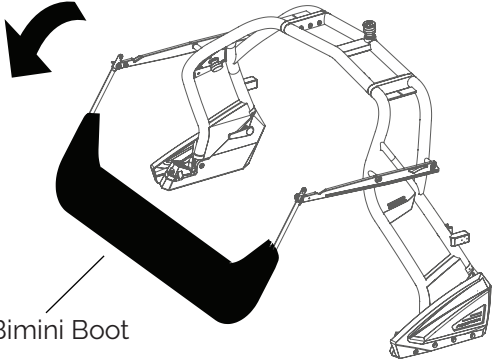
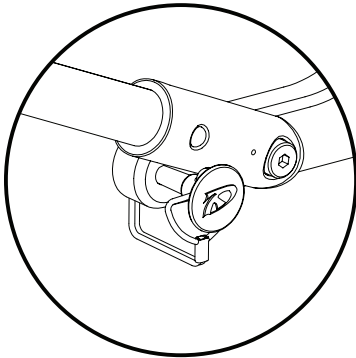
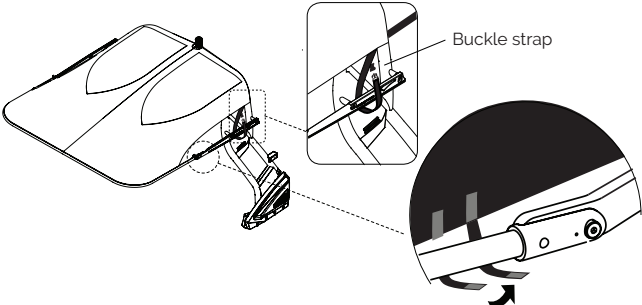
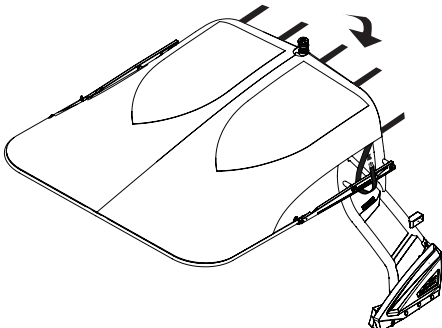
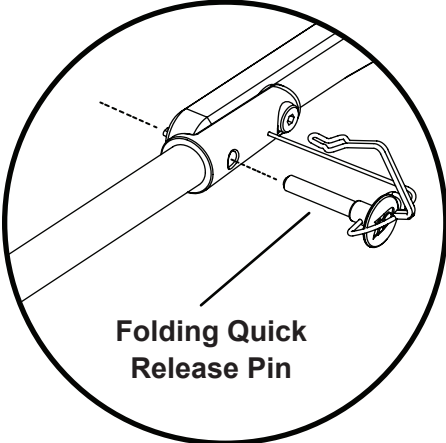


H Happy Boating!!

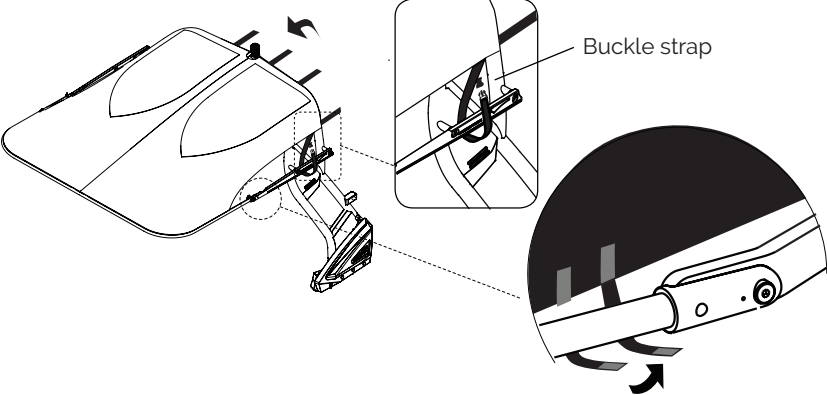
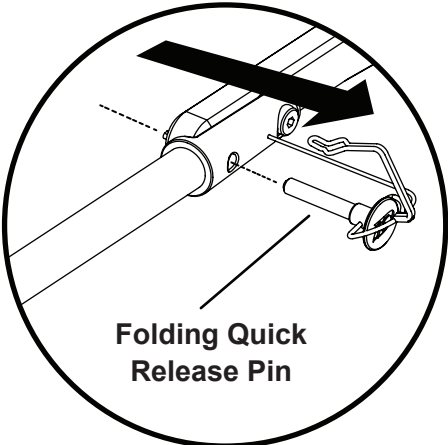
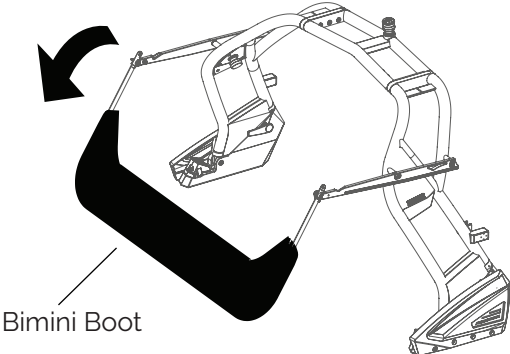
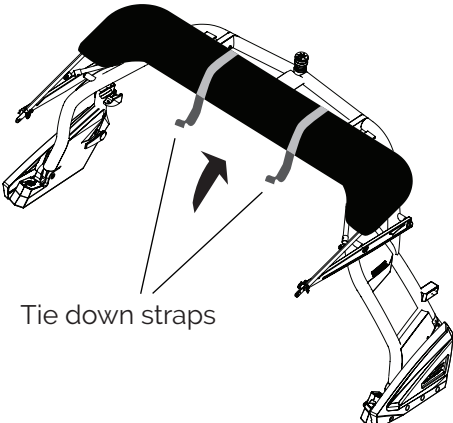
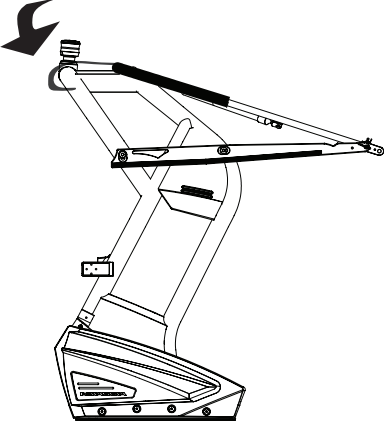
Your bimini is now ready for use.



Unfolding Your Moomba Bimini

<p>A</p>	<p>Undo the 2 straps that secure the bimini to your tower.</p>  <p>Tie down straps</p>	<p>B</p> <p>Unfold the frame from the tower. Unzip the bimini boot from the bimini frame. Unroll your fabric and middle bow</p>  <p>Bimini Boot</p>
<p>C</p>	<p>Rotate the frame upwards and insert the quick release pins into the bimini arms only.</p> 	<p>D</p> <p>Adjust and secure the Velcro straps located on either side of the bimini canvas and clip the rear buckle strap in.</p>  <p>Buckle strap</p>
<p>E</p>	<p>Attach all rear Velcro straps on the rear of the bimini. Make sure to not over tighten straps</p> 	<p>F</p> <p>Remove the pins, Pull frame down, align holes and re-enter pins. Your bimini is now ready to use!</p>  <p>Folding Quick Release Pin</p>

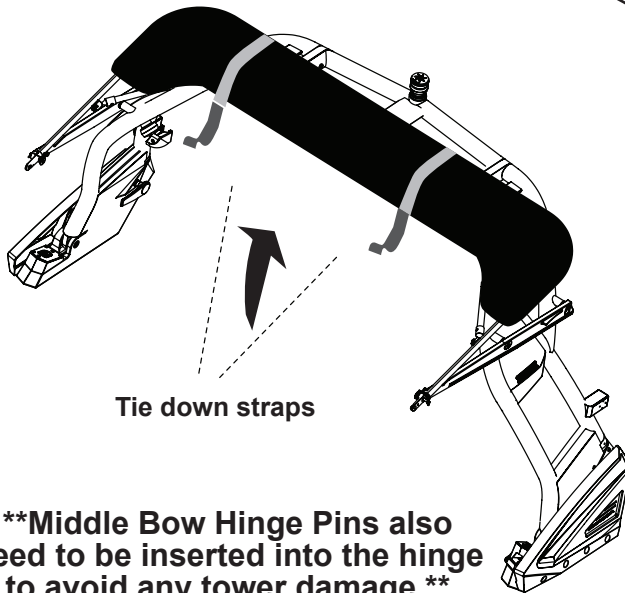
Folding Up Your Moomba Bimini

<p>A</p>	<p>Undo all Velcro straps and both buckle straps attaching the rear of the bimini canvas to the tower. Also release the straps on the side of the bimini frame.</p> 	
<p>B</p>	<p>Remove the quick release pins located on both bimini arms and lower the frame</p>  <p>Folding Quick Release Pin</p>	<p>C</p> <p>Fold the middle bow towards the front bow and wrap the fabric around both bows. Zip the bimini boot over the bows and fabric.</p>  <p>Bimini Boot</p>
<p>D</p>	<p>Fold the bimini up towards the tower until it rests on the top of the tower.</p>  <p>Tie down straps</p>	<p>E</p> <p>Loop the tie down straps over the tower tubing. Adjust the straps to tighten the bimini to the tower.</p> 

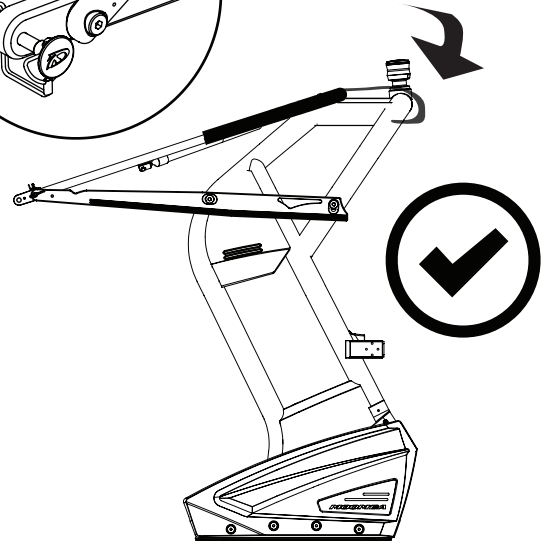
Tower folding / Trailing

A

Quick release pins must be inserted into the bimini arms for trailing to avoid damage to parts



Tie down straps



****Middle Bow Hinge Pins also need to be inserted into the hinge to avoid any tower damage.****

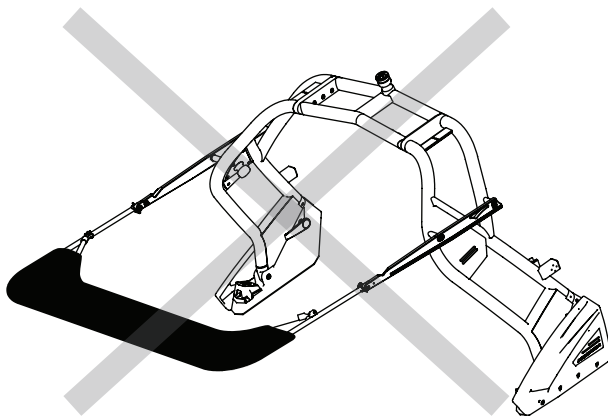
***** Illustrated is the ONLY acceptable way to safely fold your Moomba tower or trailer your Moomba boat with the bimini on*****

! ATTENTION !

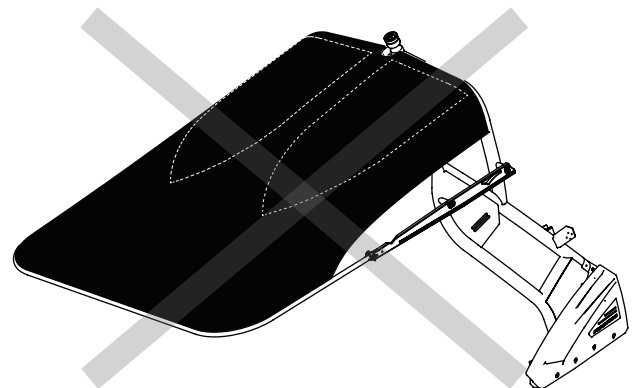
DO NOT TRAILER YOUR BOAT WITH THE BIMINI IN ITS OUTSTRETCHED POSITION

DO NOT FOLD YOUR TOWER WITH THE BIMINI IN ITS OUTSTRETCHED POSITION

DO NOT USE YOUR BIMINI IN ITS OUTSTRETCHED POSITION IN ANY HIGH WIND CIRCUMSTANCES



DO NOT FOLD THE TOWER OR TRAILER BOAT WITH BIMINI IN THIS POSITION



DO NOT FOLD THE TOWER OR TRAILER BOAT WITH BIMINI IN THIS POSITION

Tightening Your Bimini Canvas

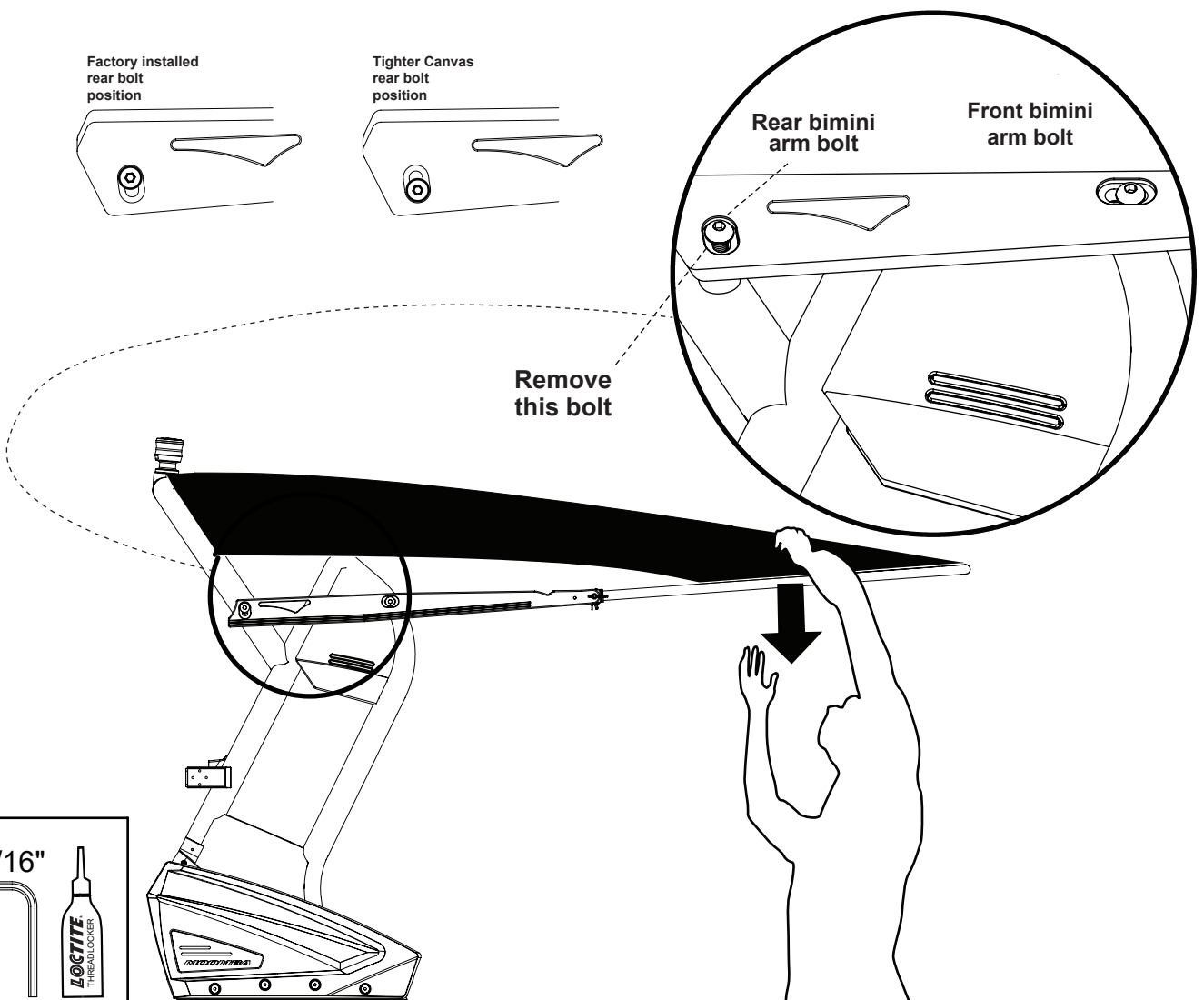
It is normal that your bimini canvas will stretch over time and use. Your Moomba Bimini has been designed to allow you to tighten your canvas as needed.

A

Canvas Tightening

This method is best executed with 2 people

Remove the rear bimini arm bolts on port and starboard sides. Do not remove the front bimini arm bolts or your fabric. Once both rear bolts are removed, re-apply threadlocker to each bolt and re-thread them loosely back into the tower. Have a friend lightly pull down on the bimini arms one side at a time. With the arm being pulled down, re-tighten the rear bimini arm bolt. Repeat on the other side.

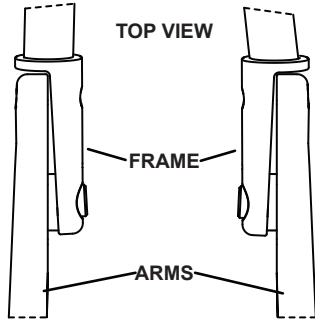


Tips and Tricks for your Bimini

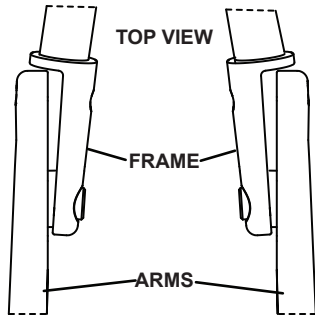
It is normal that there is potentially a slight variation from one tower bimini to another. Listed below are some tips and tricks to ensure that your bimini is installed and functioning properly. This process is not mandatory for all biminis.

A

it is possible that once your bimini is installed your frame and arms are not parallel where they pivot. This could make inserting and removing your quick release pins difficult. If you are not experiencing any issues, skip this page.



If your bimini looks like this, in Step 2 you will need to add shim washers between the forward bimini mounts and your bimini arms

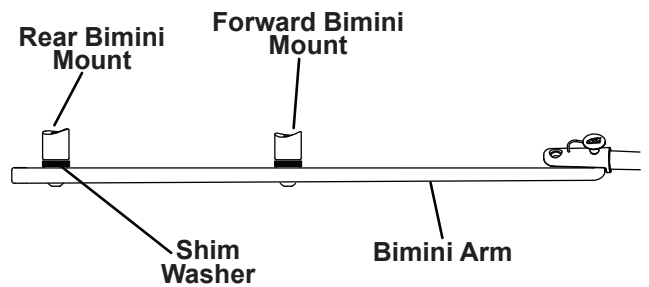


If your bimini looks like this, in Step 2 you will need to add shim washers between the rear bimini mounts and your bimini arms

B

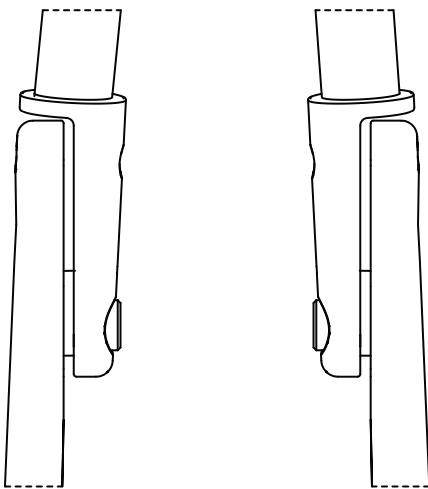
Choose one side of your tower to work on first. Determine which bimini mount the shim washers will need to be added to. Completely remove the bolt that secures the bimini arm to your chosen bimini mount. Loosen the other bimini arm bolt. Add the shim washer(s) in between the chosen bimini mount and bimini arm (In some cases 2 washers may be required under each arm). Re-insert the bolt with loctite applied. Remove the loosened bolt, apply Loctite and re-insert. Tighten down the front and rear bimini arm bolts in the same position they were in prior to loosening them. Repeat on the other side of your tower.

TOP VIEW



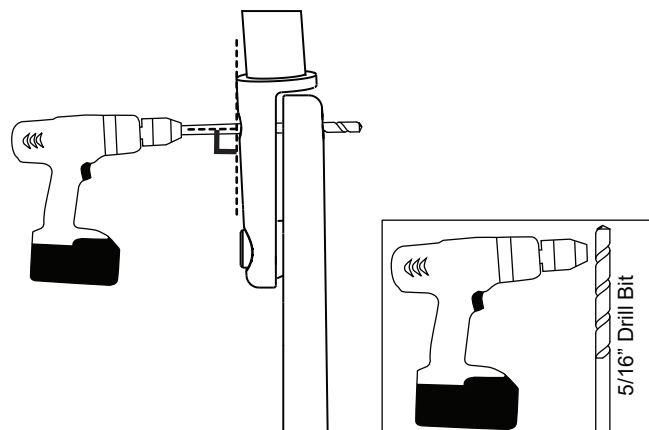
C

Now that your shim washers have been added your frame and arms should be parallel or much closer. Test removing and inserting your quick release pins. If it is still difficult to remove or insert the pins proceed to the next step.



D

If your quick release pins are still difficult to remove and insert with the addition of the arm shim washers, Roswell recommends using a drill with a 5/16" drill bit to clean out the holes. Drill perpendicular through the frame and bimini arms at the same time. This will help with the alignment and ensure an accurately aligned hole.



Folding Your Tower

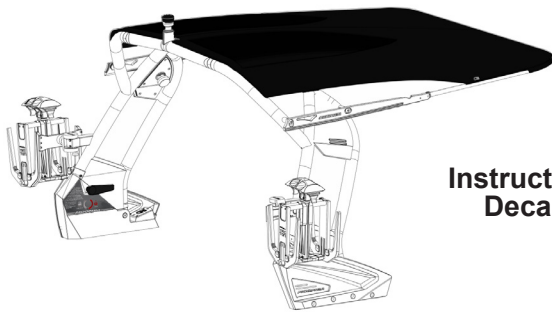
A

BEFORE ATTEMPTING TO FOLD YOUR TOWER :

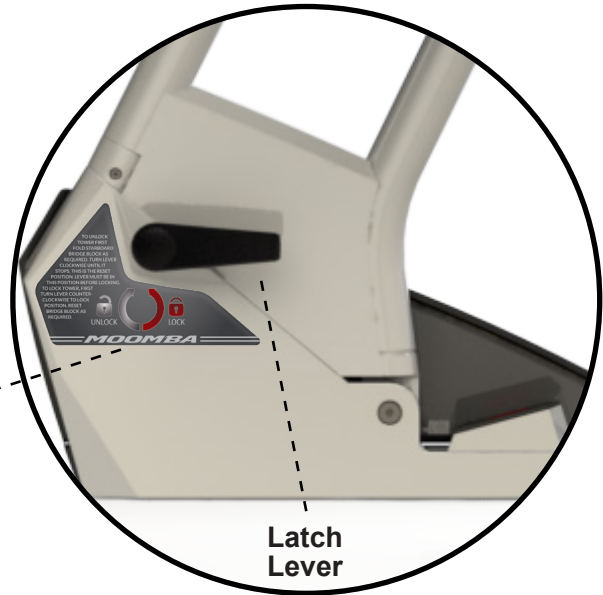
- Ensure all boards have been removed from racks.
- Ensure swivels are locked into either the inside or outside positions.
- Ensure your bimini is folded against the tower and secured.
- Ensure no body parts are near the folding area of the tower.
- Ensure that no one is sitting in the way of the folded tower.

B

Unlocking the latches



Instruction Decal



Latch Lever

To fold your tower, first unlock the latches using the lever illustrated. Follow the instructions indicated on each decal. The decal instructions are different on each side. Prior to unlocking the second latch ensure your are ready to support and slowly lower the weight of the tower.

PORT Side Unlocking:

Turn lever **CLOCKWISE** until it stops.
This is the reset position.

PORT Side Locking:

Turn lever **COUNTERCLOCKWISE**.

STARBOARD Side Unlocking:

Turn lever **COUNTERCLOCKWISE** until it stops.
This is the reset position.

STARBOARD Side Locking:

Turn lever **CLOCKWISE**.

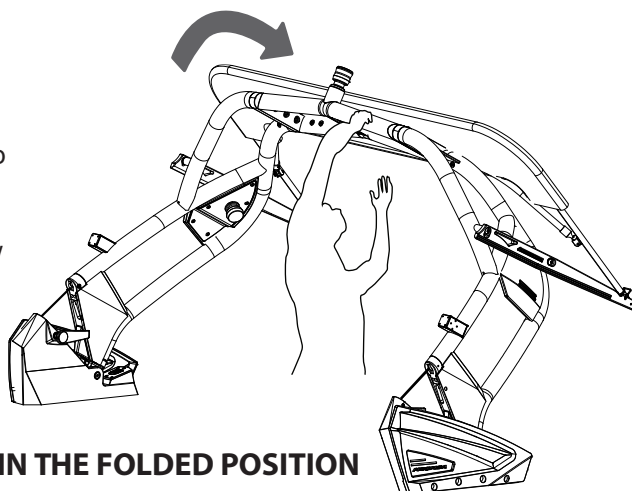
B

Unlocking the latches

With both latches released, slowly lower the tower until it rests at the stop position.

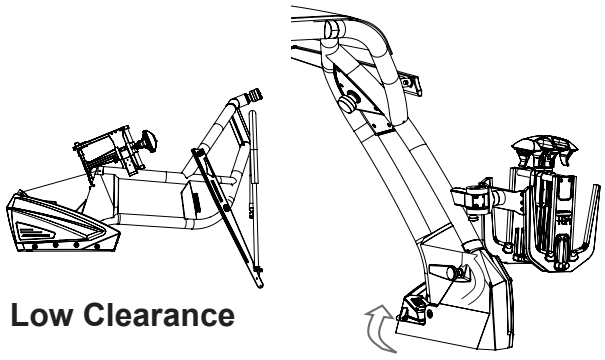
This folded position is intended for low speed boat operation such as

- Parking boat in garage
- Boating under a bridge



DO NOT TRAILER YOUR TOWER IN THE FOLDED POSITION

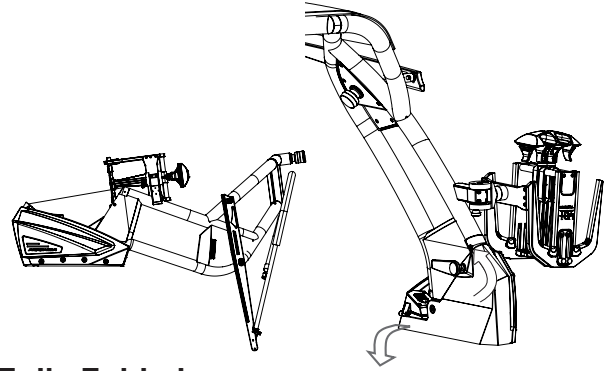
C



Low Clearance

The Moomba Pro tower has a bumper that allows the tower to fold partially to get under low objects such as bridges when boating. To do this make sure that the bumper is folded up on the port side of the tower. then release the cam latches and fold the tower.

D



Fully Folded

To fully fold the Moomba pro tower flip the bump stop on the port side down and then release the cam latches and fold your tower.

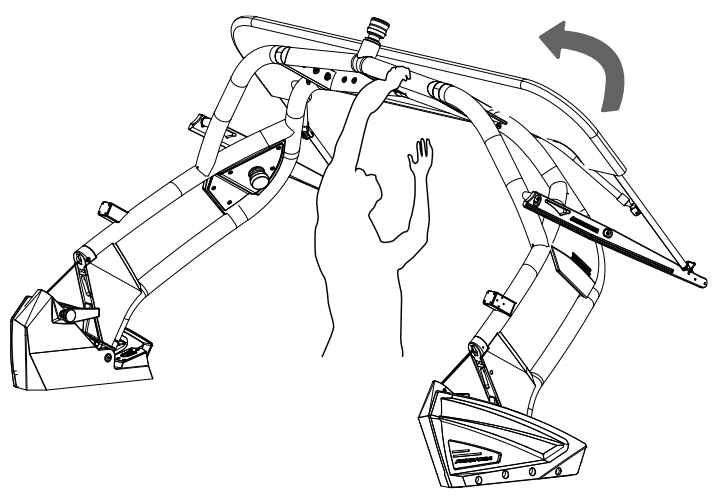
B

Rise the tower up

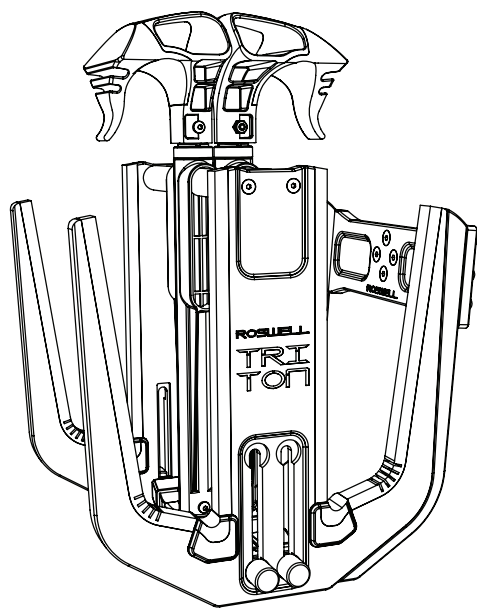
To raise the tower up repeat steps B & C in reverse.

PORT Side Locking:
Turn lever **COUNTERCLOCKWISE**.
PORT Side Unlocking:
Turn lever **CLOCKWISE** until it stops.
This is the reset position.

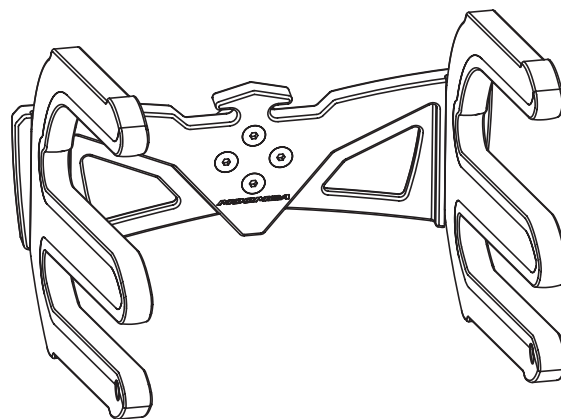
STARBOARD Side Locking:
Turn lever **CLOCKWISE**.
STARBOARD Side Unlocking:
Turn lever **COUNTERCLOCKWISE** until it stops.
This is the reset position.



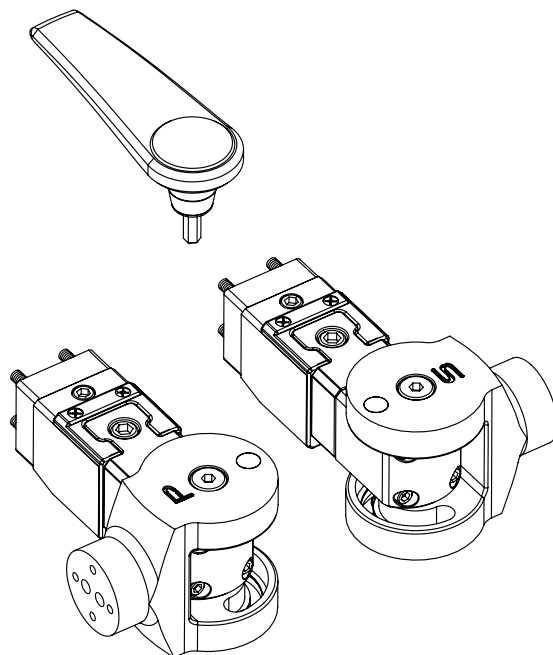
Board Racks/ Swivel/ Quick Release



Triton Board Rack #C915-118179



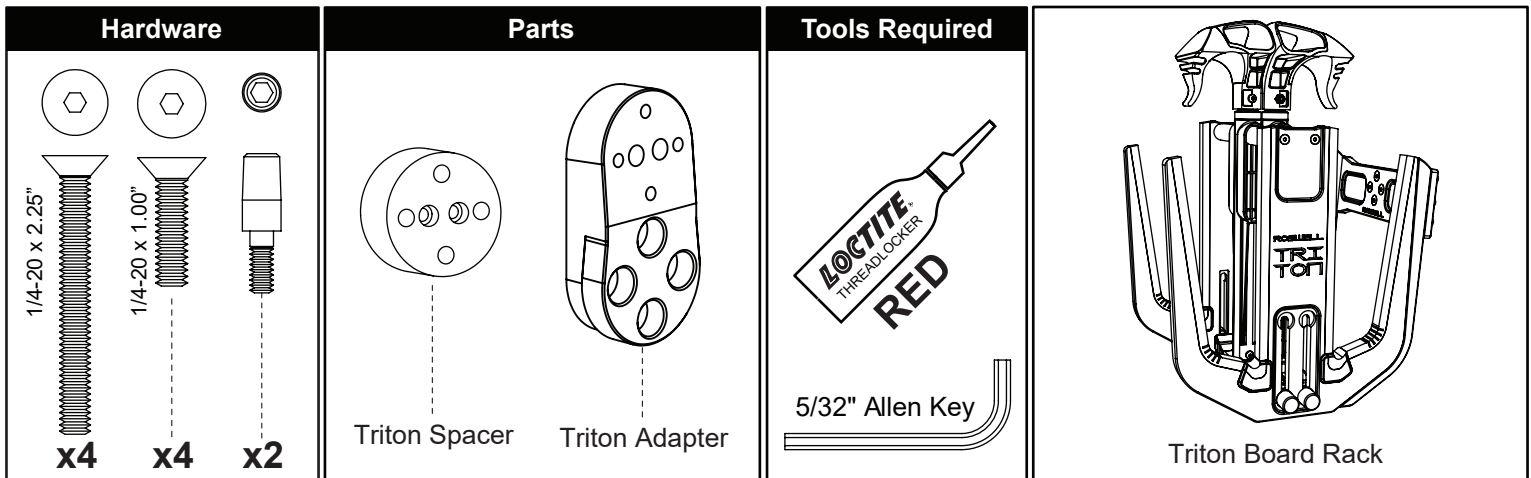
Wake Surf #C915-116071



Push Button Swivel with Board Rack Quick Release #C915-116063

Information: info@roswellmarine.com
If you have any questions please call : 1-321-638-1331

Triton Board Rack Assembly Instructions



ATTENTION



- Always ensure your boards are securely **fastened** in place by the rack. Give the board a quick tug to check it is secure before setting off.
- Always ensure your swivel is properly **locked** before moving your boat. Give the rack a tug and visually check locking pin to make sure it is secure after you have put the swivel in a new position.
- Never insert boards that are beyond the stated maximums and minimums for the rack.
- Always swivel your racks inboard when docking and/or trailering your boat.
- Never trailer your boat with boards in the racks. Racks are for on water use only.
- Check all bolts on the rack and swivel for tightness before using your boat. If any bolts are found to be loose remove them, apply red thread lock and re-tighten the bolts.
- The driver should check their lines of sight before operating the boat being sure nothing in the rack blocks their safe view and operation of the boat.
- Be aware of your rope making sure it does not get wrapped around the board rack, the boards, or any other objects.



Triton Rack Specific



- 20" maximum for the narrow board setting and 23" maximum for the wide board setting.
- 14" minimum for the narrow board setting and 17" minimum for the wide board setting.

MOUNTING OPTIONS

There are 4 scenarios for mounting a board rack provided by Moomba.

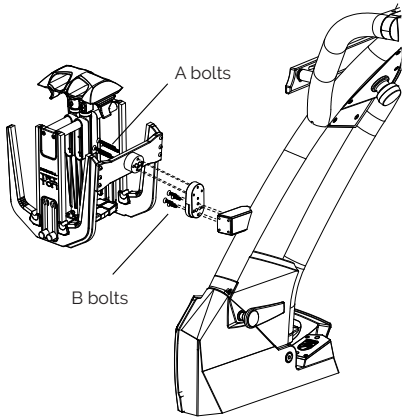
- 1 : You have a Triton rack and can mount the rack in a fixed position.
- 2 : You have a Triton rack and can mount the rack to a Moomba Swivel with Quick Release.
- 3 : You have a Board Rack and can mount the rack in a fixed position.
- 4 : You have a Board Rack and can mount the rack to a Moomba Swivel with Quick Release.

A Fixed mounting

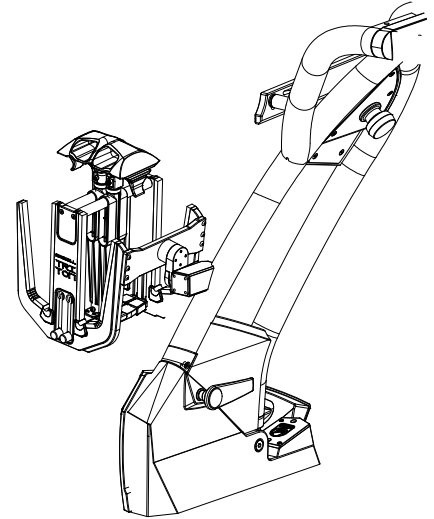


1 : Mount the adapter to the tower block with the 4 (B) bolts included with your adapter. Add a drop of red threadlocker to each bolt first.

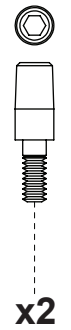
2 : Mount the triton rack to the adapter using the 4 long (A) bolts provided with your rack. Add a drop of red threadlocker to each bolt first.



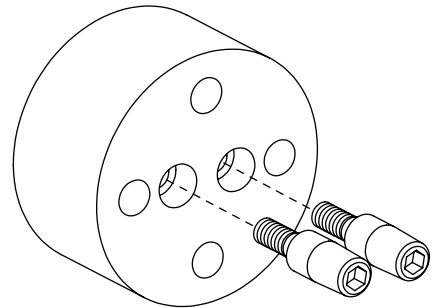
This is how your Triton rack installation should look.



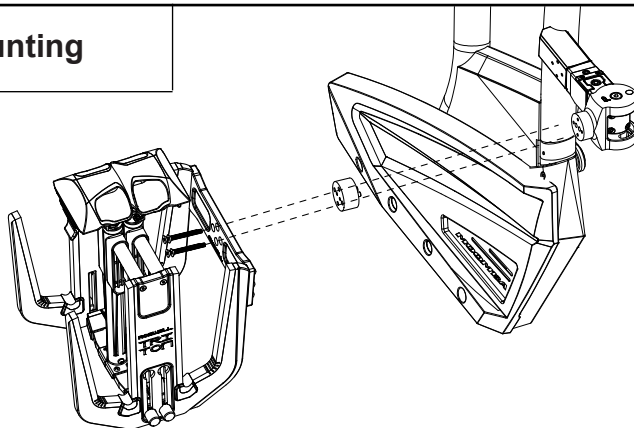
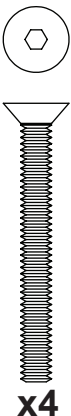
A Swivel mounting



If you are mounting Triton to a swivel first verify that your swivel has 2 holes to accommodate the 2 alignment pins. If it does, thread the 2 alignment pins into the spacer. Apply threadlocker to the 2 pins first. If it doesn't move on to step E.



B Swivel mounting

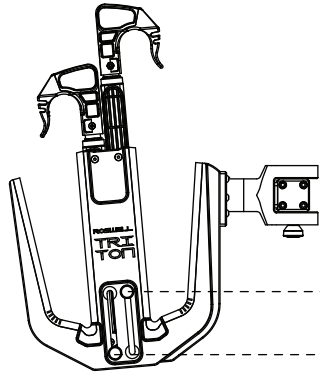


If you are mounting your Triton rack to a swivel, use the 4 bolts provided and the spacer. Apply threadlocker to the 4 bolts first.



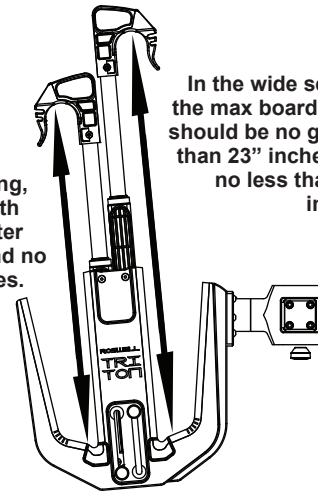
A

Your Triton rack is designed to be adjustable to fit just about any size of wakeboard, wakesurfer or wakeskate. There are 2 settings, one for narrower boards, one for wider boards.



Wide board setting

In the narrow setting, the max board width should be no greater than 20" inches and no less than 14" inches.



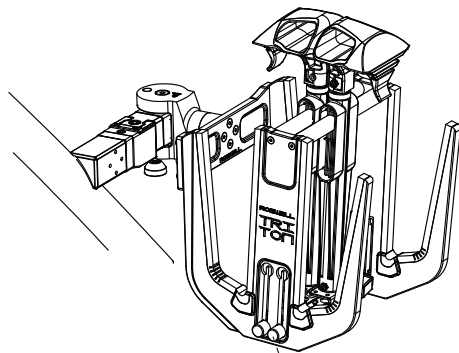
In the wide setting, the max board width should be no greater than 23" inches and no less than 17" inches.

Narrow board setting

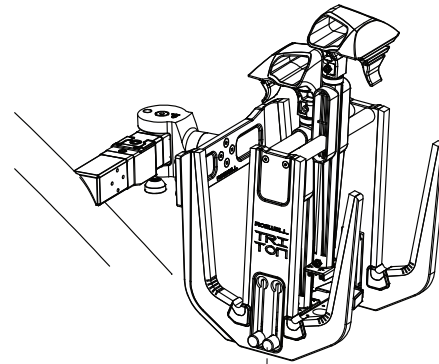
B

Adjust your telescopic arms one at a time. To adjust your telescopic arms loosen the knobs on both sides of the rack for the same arm until the knobs are past the counterbored holes they sit in. At this point you will be able to slide the whole arm assembly up or down to the next position where you will then retighten the knobs.

Make sure your adjustment knobs are tightened periodically.



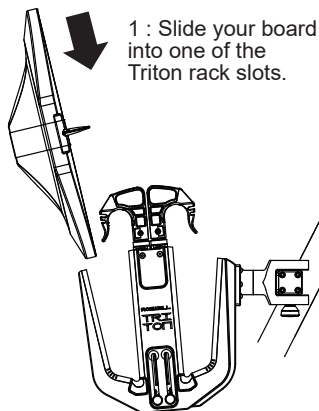
Knob to loosen/tighten



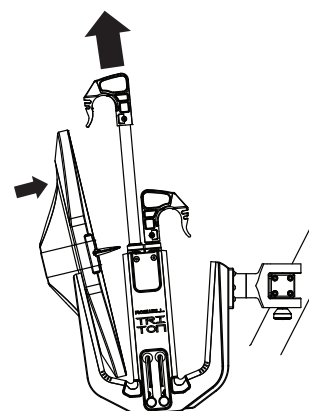
Tighten

C

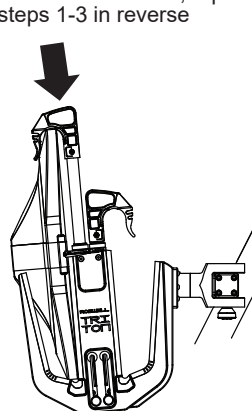
Inserting Boards



1 : Slide your board into one of the Triton rack slots.

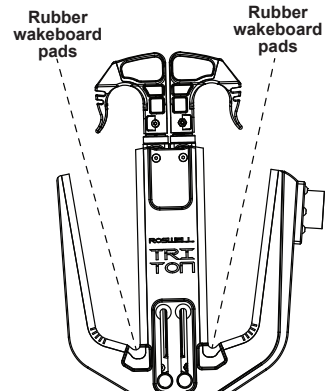


2 : Pull up on the telescopic arm and flip your board towards it.



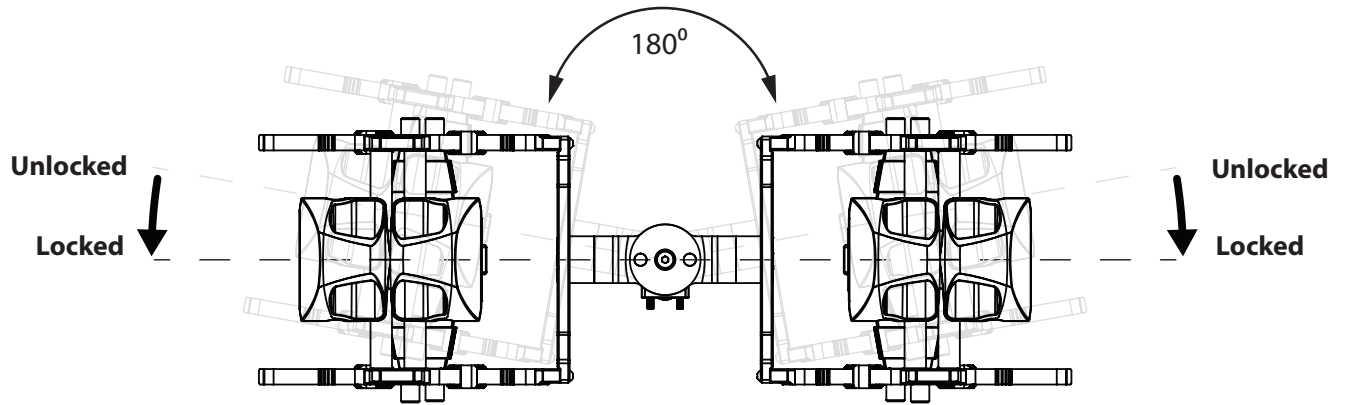
3 : Let the telescopic arm clamp down over your board. To remove a board, repeat steps 1-3 in reverse

Ensure wakeboards with sharper edges are located within the harder rubber wakeboard pads in the tine slots. This is essential to avoid damaging the softer foam protection intended for fragile surfboards and wakesurfers.

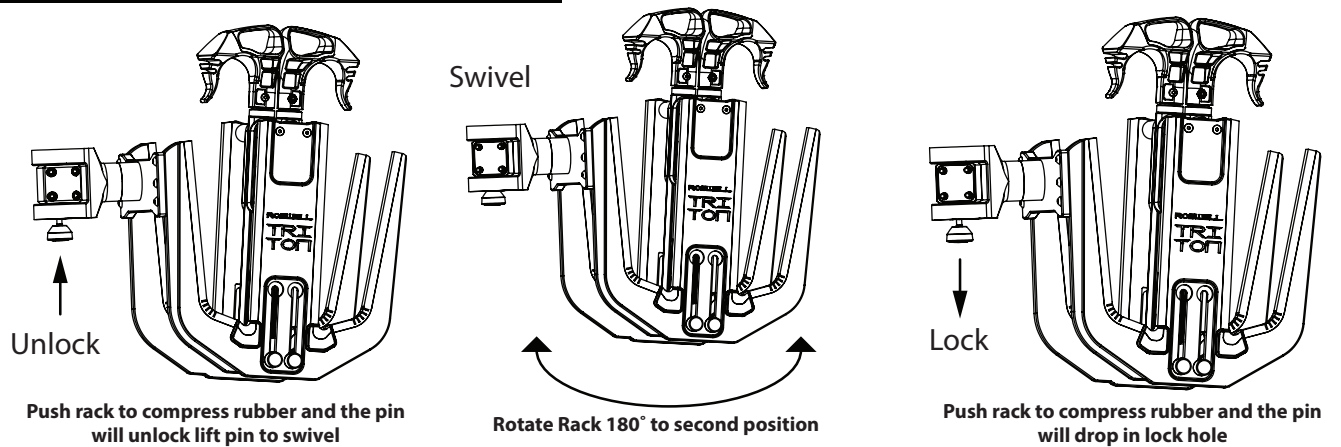


A Swivel Operation

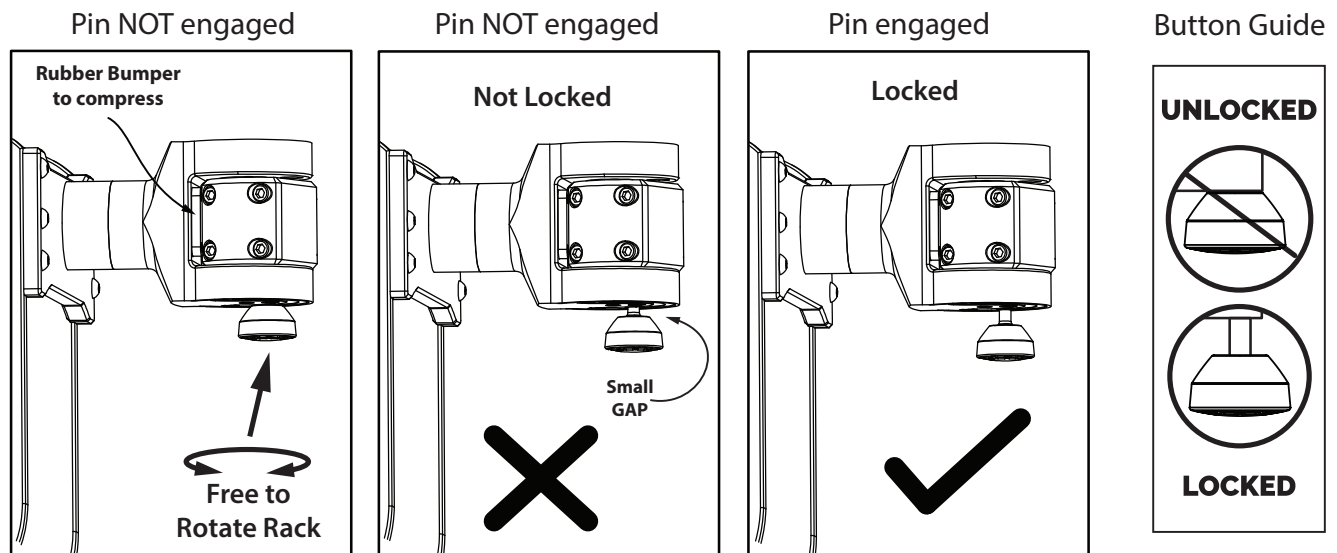
Swivel assemblies must be completely locked to avoid damage to boat or injury to occupants. Proper swivel operation is crucial to ensure racks do not swing into boat unintentionally. To ensure proper engagement and releasing of locking pin, swing racks until they compress the rubber bumper at end of travel. Compressing the bumper is necessary to lock AND unlock the locking pin.



How to properly operate the Swivel



How to identify if your swivel is locked

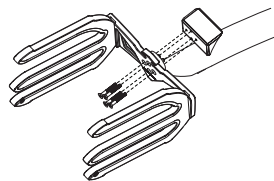


Wake/Surf Rack Assembly Instructions

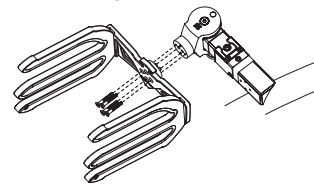
Hardware	Parts	Tools Required	
<p>1/4-20 x 1.75" x8</p> <p>CUSTOM x4</p> <p>1/4-20 x 1.00" x12</p>	<p>Tines & Bungee x2</p> <p>Backing Plate x2</p> <p>Spacer x2</p>	<p>LOCTITE THREADLOCKER RED</p> <p>5/32" Allen Key</p>	

**** BOARD RACK BUNGEE CORD NOT ILLUSTRATED FOR IMAGE CLARITY ****

Below are the recommended mounting options for Roswell board racks.
 Installation instructions available with respective mounting products.



Fixed Tower Mount



Quick Release Swivel Mount

A Apply RED threadlocker to 6 button head bolts and mount the backing plate to a set of tines. Make sure the tines are properly seated in the backing plate grooves. Torque bolts to 15 ft. lbs.

5/32"

x6

B Place the spacer behind the backing plate, and mount following the next step.

C Apply red threadlocker to 4 flat head bolts and mount the rack to the tower ensure the spacer is mounted between the rack and the tower. Torque bolts to 15 ft lbs.

5/32"

x4

Board Rack Quick Release Assembly Instructions

Hardware	Tools Required	Parts	
<p>3/8-16 x 1.5" A x2</p> <p>5/16-18 x 1.5" B x2</p> <p>1/4-20 x 1.0" C x8</p> <p>5/16-18 x 0.75" D x2</p>	<p>LOCTITE THREADLOCKER RED</p> <p>1/4" Allen Key 5/16" Allen Key 3/16" Allen Key</p>	<p>QR Tool</p> <p>QR Tower Adaptor</p> <p>QR Male Adaptor with Swivels</p> <p>QR Female Adaptor</p>	

A Apply RED threadlocker to 4x C bolts and mount the QR tower adaptor to the tower mount as illustrated. Torque bolts to 15 ft lbs.

C bolts

3/16"
C x4

LOCTITE
THREADLOCKER
RED

B First, place the QR Female adaptor onto the QR Tower adaptor. Then, apply RED threadlocker to a B bolt and a D bolt and fasten as illustrated. Torque bolts to 15 ft lbs.

D bolt

B bolt

D x1

B x1

1/4"
B x1

LOCTITE
THREADLOCKER
RED

C Apply RED threadlocker to the Swivel's 4 (A) bolts. Mount the QR male adaptor to the Swivel. Torque bolts the (A) bolts to 15 ft lbs.

3/16"
A x4

LOCTITE
THREADLOCKER
RED

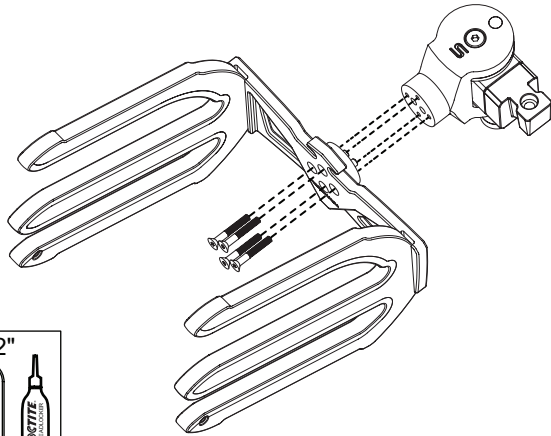
D Make sure to apply RED Loctite to the board rack's 2 custom bolts and assemble the spacer to rear of the backing plate before continuing. Torque bolts to 9.5 ft lbs.

5/32"
D x2

LOCTITE
THREADLOCKER
RED

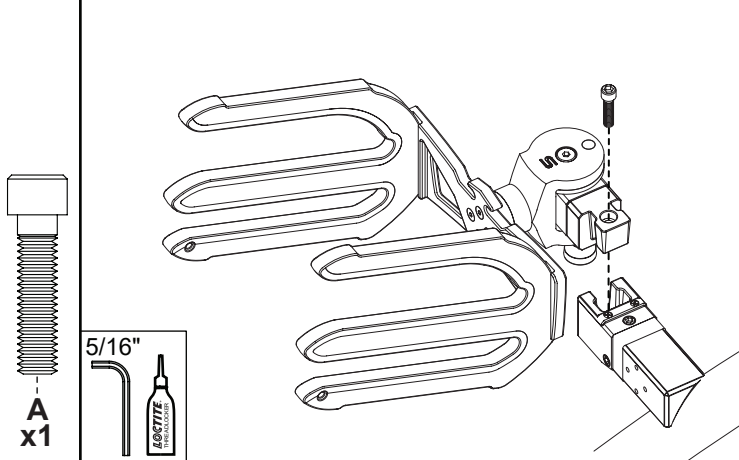
E

Apply RED Loctite to the board rack's 4 bolts and mount the rack to the Swivel. Torque bolts to 15 ft lbs.



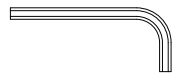
F

Carefully slide the Male Adaptor into the Female Adaptor, and fasten together with an A bolt and your QR tool.

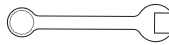


Moomba Pro Weight Assist Adjustment

Tools Required



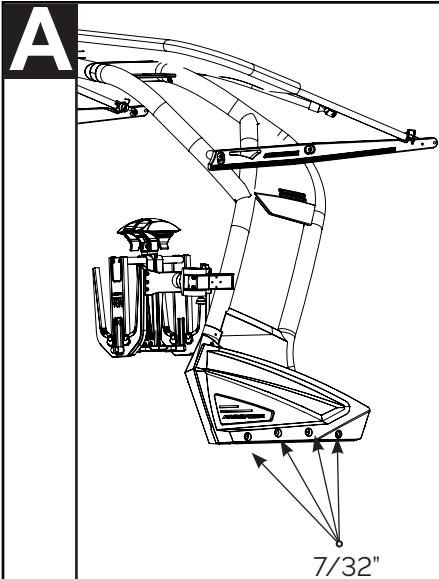
7/32"



3/4"

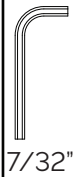


LOCTITE
THREADLOCKER
RED

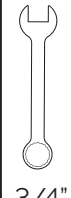
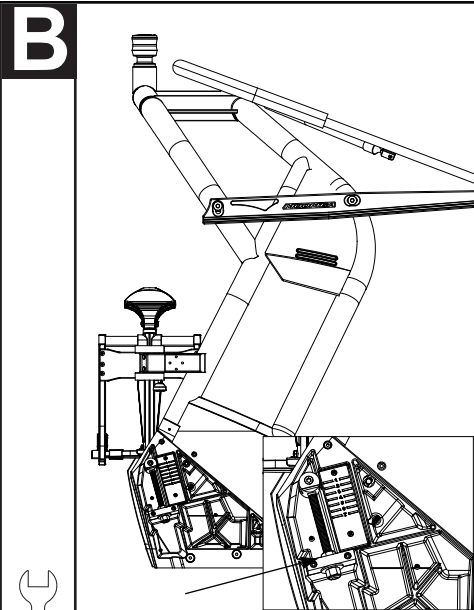


7/32"

Take a 7/32" Allen Key and loosen the 4 bolts holding the cover plate on.

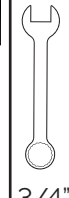
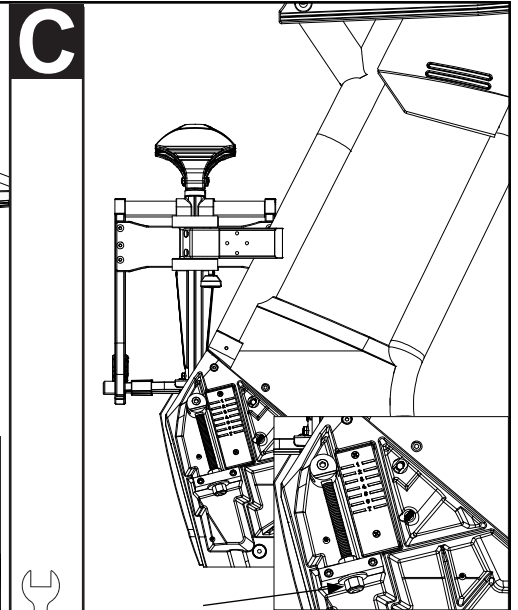


7/32"



3/4"

Using a 3/4" box end wrench loosen the top locking nut.

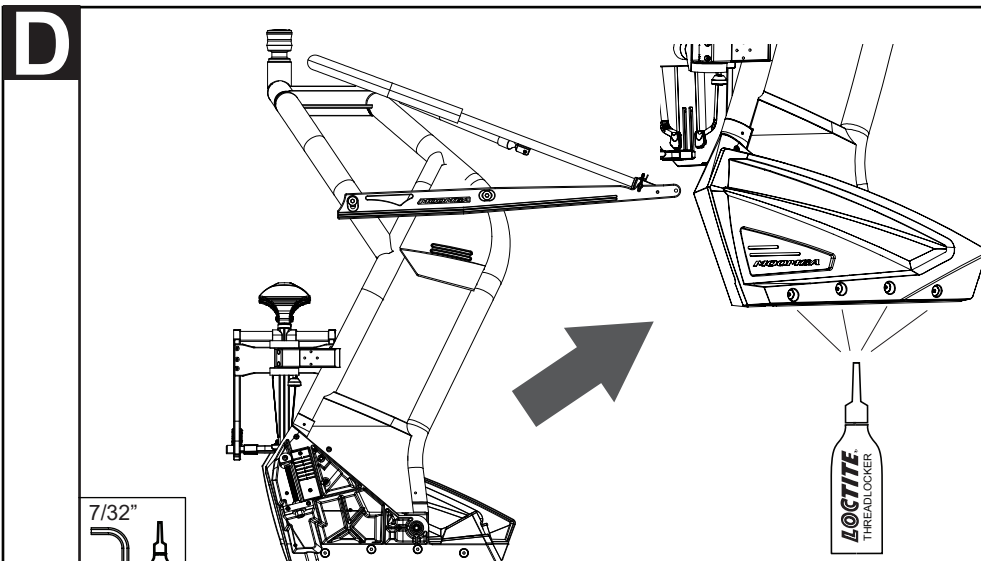


3/4"

Now that the top locking nut is loosened use the same 3/4" wrench and adjust the system using the lower brass nut.

NOTE:

This will have to be repeated for both sides. Take note of the position the marker is in and repeat on the other side.



7/32"



LOCTITE
THREADLOCKER
RED

Apply Red threadlocker to the 4 side plate bolts and install back in position.

Wiring Diagrams

Tower Wiring / Speaker wiring

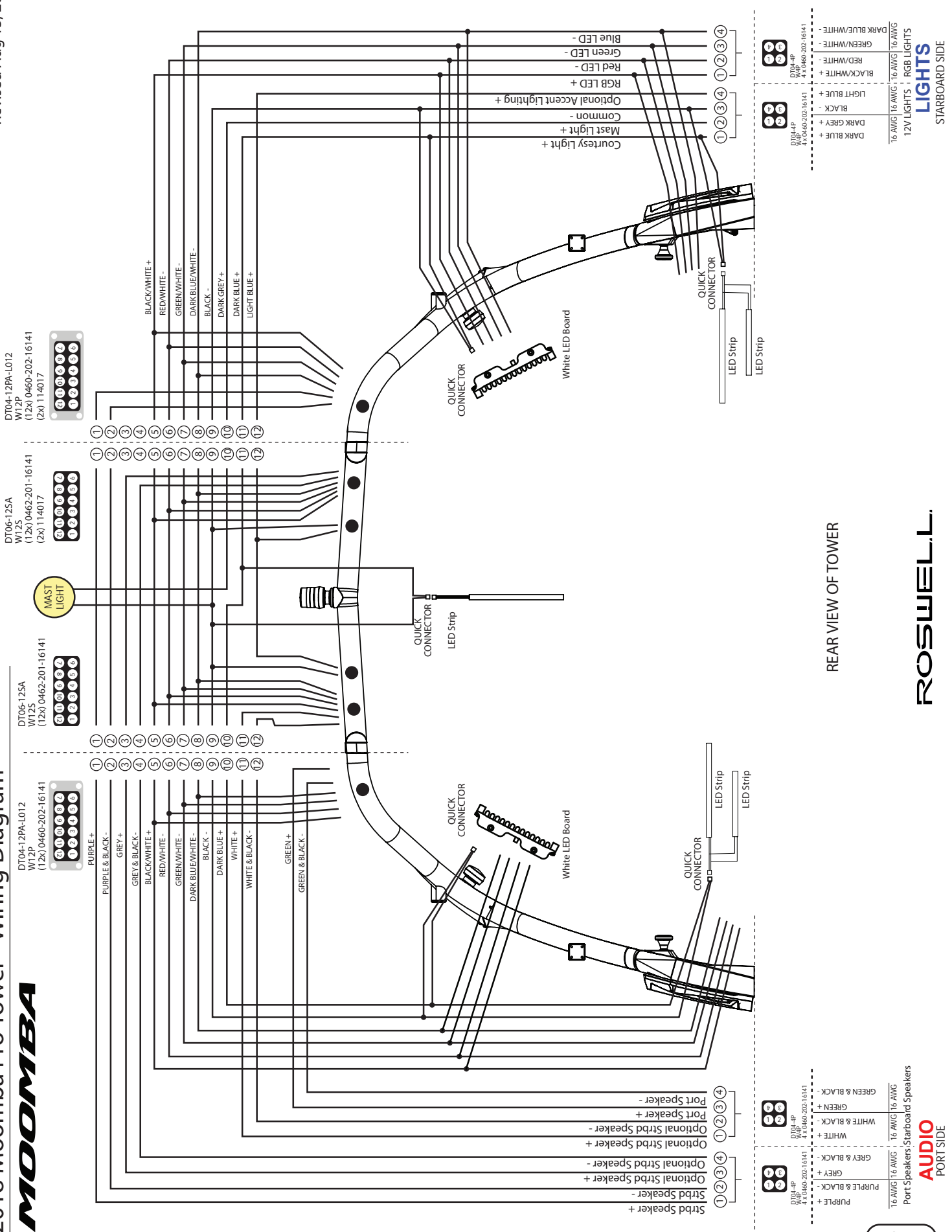


2018 Moomba Pro Tower - Wiring Diagram

MOOMBA

Revised Aug 13, 2018

www.roswellmarine.com



REAR VIEW OF TOWER

AUDIO
PORT SIDE

ROSWELL
STARBOARD SIDE

LIGHTS
STARBOARD SIDE

