

ROSWELL.

www.roswellmarine.com

Nautique G Series Veralex Mirror

Installation & Usage Instructions

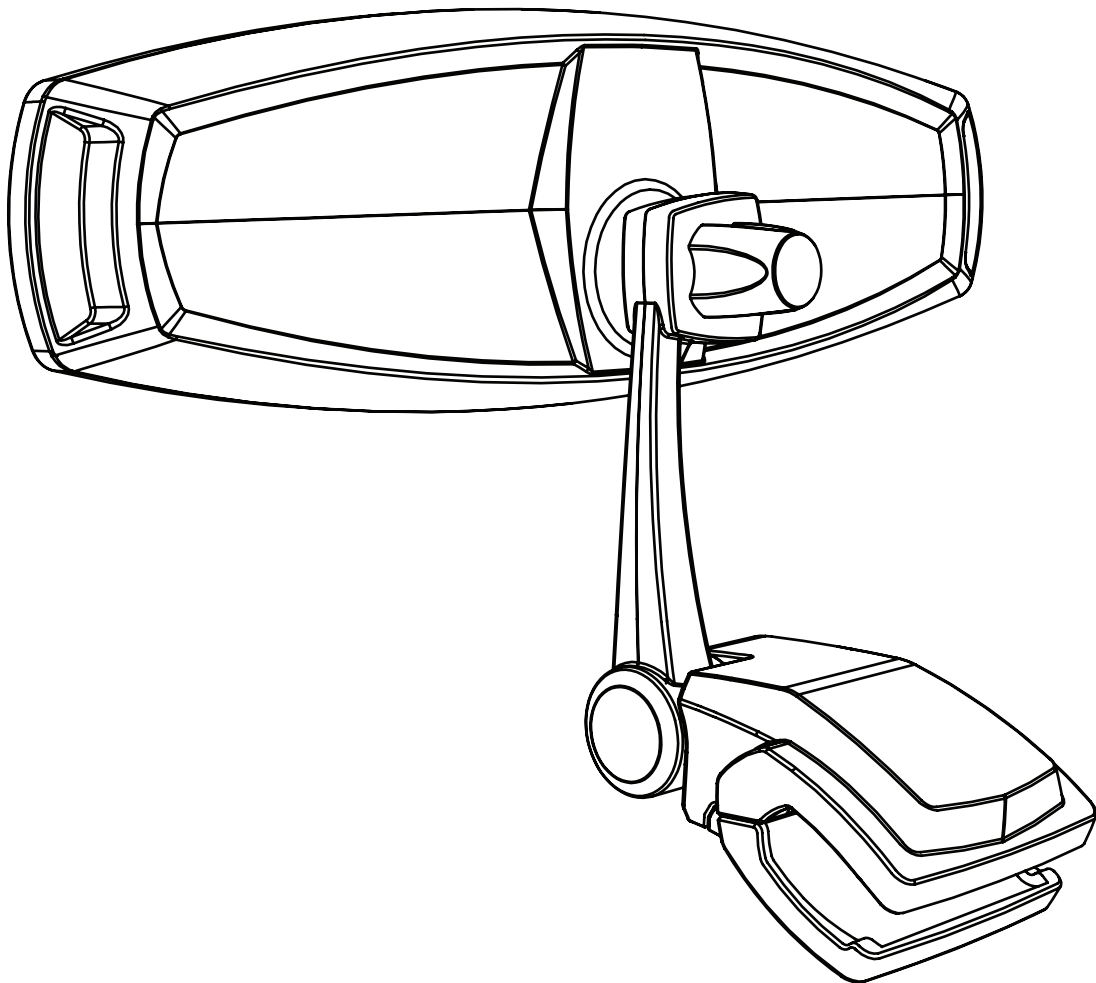

Part # C917-190015
& # C917-190016

Information: info@roswellglobal.com

If you have any questions please call : 1-321-638-1331

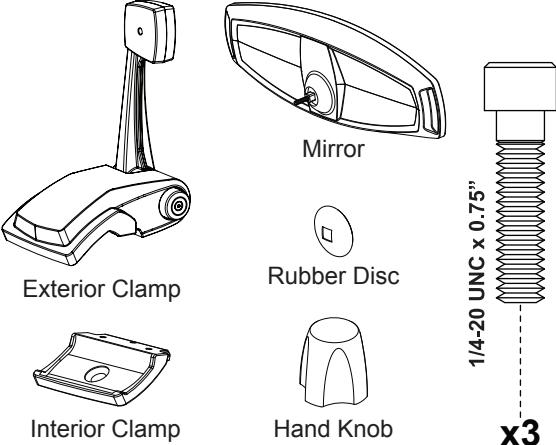
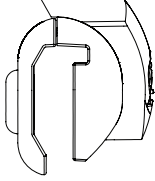
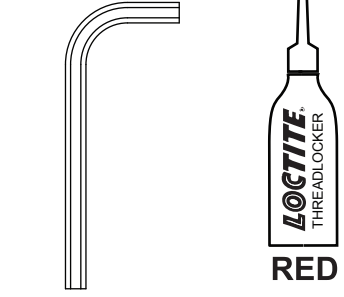

C917-190015 CONTENTS	C917-190016 CONTENTS	TOOLS NEEDED
 <p>Exterior Clamp</p> <p>Interior Clamp</p> <p>Mirror</p> <p>Rubber Disc</p> <p>Hand Knob</p> <p>1/4-20 UNC x 0.75" x3</p>	 <p>Mirror Clamp Inserts</p>	 <p>3/16" Allen Key</p> <p>LOCTITE THREADLOCKER RED</p>

! ATTENTION !

Roswell strongly recommends that a routine inspection of hardware and components be done to ensure proper function and safety and to maximize product life. If bolts are found to be loose, discontinue use until red threadlocker is re-applied and bolts are re-tightened.

A

Place each half of the header insert set into the exterior clamp and interior clamp (exterior clamp shown upside-down).

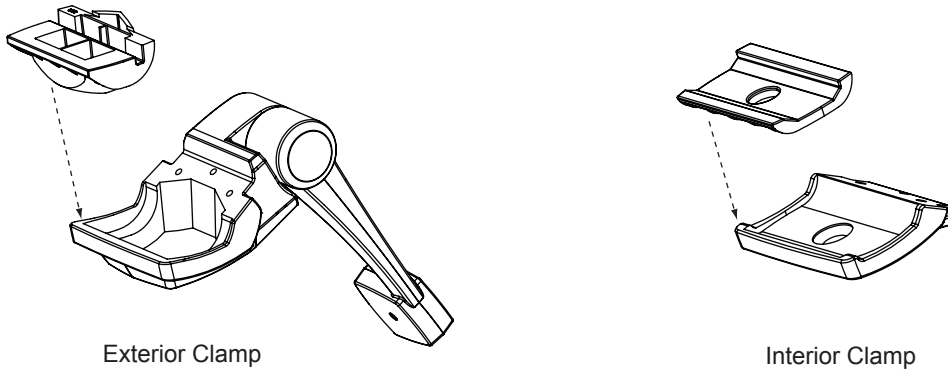

B

Locate the interior clamp and insert on the starboard windshield header, where you would like the mirror to be. Hold the interior clamp in place with one hand.

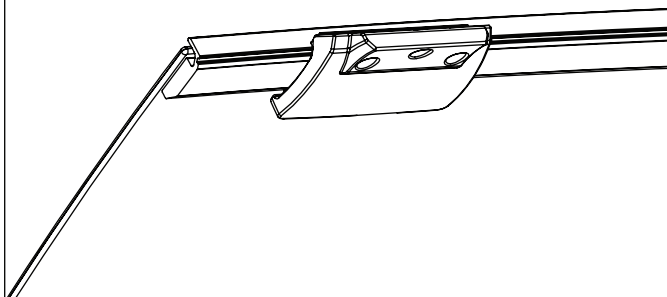

C

Locate the exterior clamp and insert above the interior clamp. Hold the two clamp sections in place with one hand.

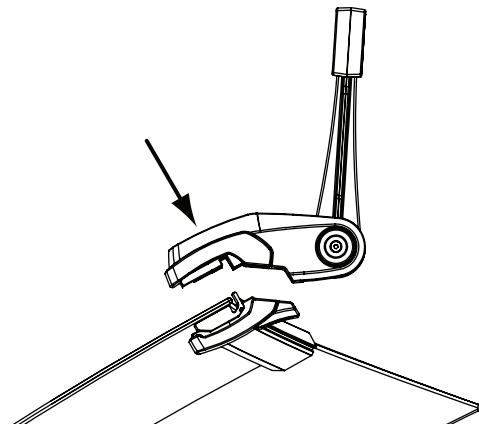

D Using one of the bolts provided with your mirror arm thread into the center hole through the two clamp sections, just enough to hold them in place. Do not fully tighten yet.

x1 3/16"

E Apply RED Loctite to the other two bolts provided and thread the bolts in the remaining two holes. Remove the center bolt from step E, apply Loctite, and re-fasten. Do not fully tighten these three bolts yet.

x2 3/16" RED

F To properly tighten the clamp sections together it is important to follow a tightening sequence. Start by tightening the center bolt two turns, then tighten each of the side bolts two turns. Repeat until the two clamp halves are touching and no gap is apparent. Make sure all bolts are tight.

If any excessive resistance is felt during tightening, do not force the bolt(s). This could strip the threads on your part. Try loosening the bolt(s) and repeating the tightening sequence.

3/16"

G Assemble the mirror to the mirror clamp. Make sure the rubber disc is assembled between the mirror housing and the mirror clamp. Also make sure to align the square fitting on the back of the mirror with the one on the clamp. Tighten the mirror in place by threading the hand knob on to the mirror bolt.

By loosening the hand knob, you are able to adjust the mirror in all directions. Simply re-tighten the handle once the mirror is at your preferred angle.

H

To move the mirror out of the way for trailering or simply to have it out of the driver's field of view, please follow these steps: First, grab the mirror extension with your right hand while with you push the black button on the left side of the mirror with your left hand. Second, rotate the mirror to one of the four locking positions. Third, lock the mirror by releasing the button, the mirror extension will move back into the lock position. Make sure the mirror becomes completely seated prior to letting go of the extension with your right hand.

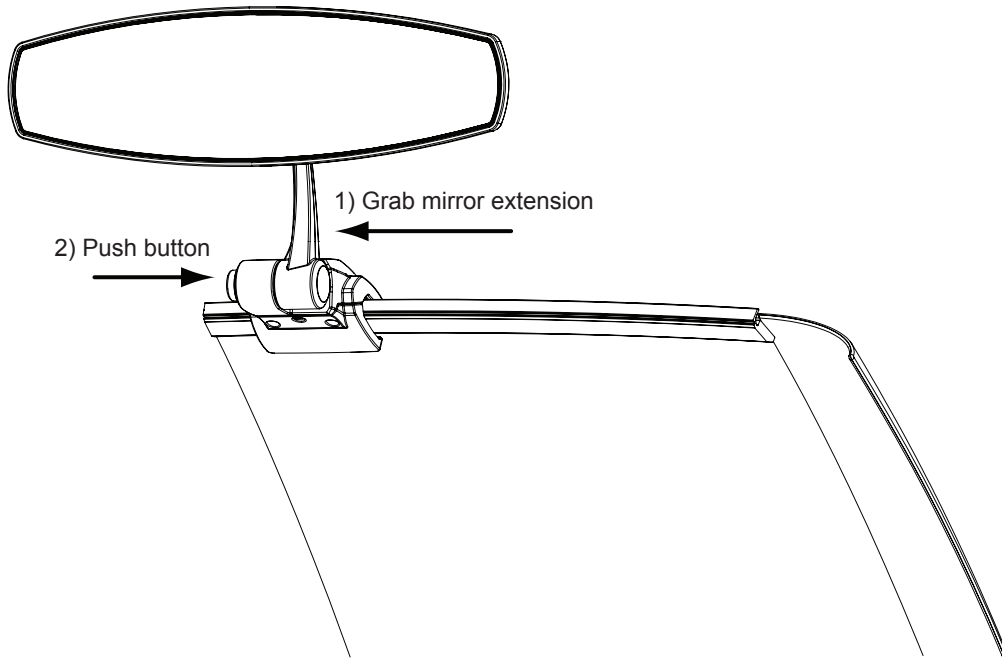

3) Rotate then lock

